

# Speed Controller with One-touch Fitting

## AS Series

### Push-lock Type

RoHS

Reduces labor time!

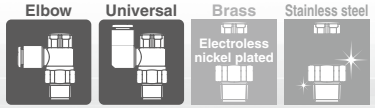

Easy to use

### Push-lock type

- Easy to lock

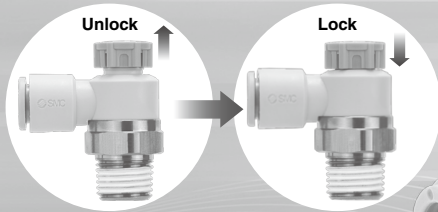

### Larger knob

Body size	ØD (mm)
1	9.4
2	12 (Port size 1/8)
3	16.6
4	18.8



### Improved tube insertion/removal

Max. Insertion force: **30%** (8 N) reduction

Max. Removal force: **20%** (5 N) reduction\*

\* Tube pulling out strength is ensured to be equivalent to current model.

More space beneath the tube.  
Easier installation/removal of the tube.

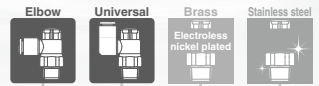
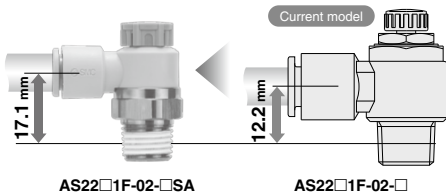

Sealant/Gasket seal  
M/UNF/R/NPT

P.554 P.554 P.554 P.667



Face seal  
R/NPT/G

P.564 P.564 P.564 P.667

\* Only G thread

\* Only G thread



Gasket seal  
Uni

P.625 P.625 P.625



AS-F  
TMH  
ASD  
AS  
AS-FE  
KE  
AS-FG  
AS-FP  
AS-FM  
AS-D  
AS-T  
ASP  
ASN  
AQ  
ASV  
AK  
VCHC  
ASR  
ASQ

## Easy tool-less one push-lock

### Push-lock type

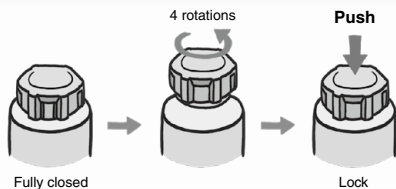

### Current model

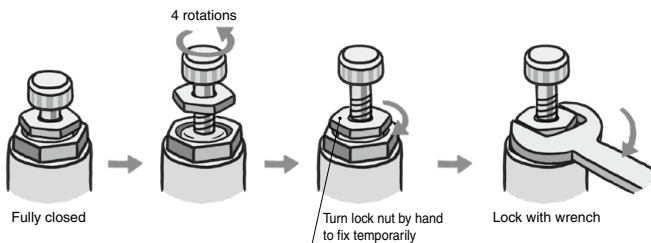

## Easy to turn large knob

### Push-lock type



Easy to turn large knob  
Easy to make fine adjustments

### Current model

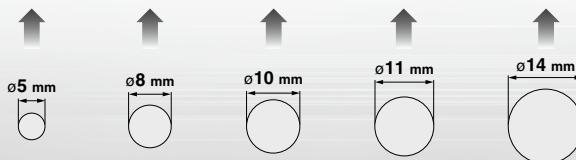

Hard to hold small knob  
Hard to make fine adjustments

## Flow rate reproducibility



### Improved reproducibility of flow rate

Stable knob position when fully closed (no flow rate) onto the contact face stopper (rotating stopper). Small variations in flow rate depending on the number of knob rotations

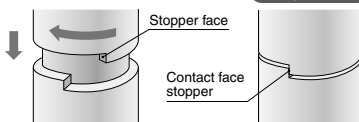

## Lightweight

Weight  
Up to approx.  
**50% lighter**

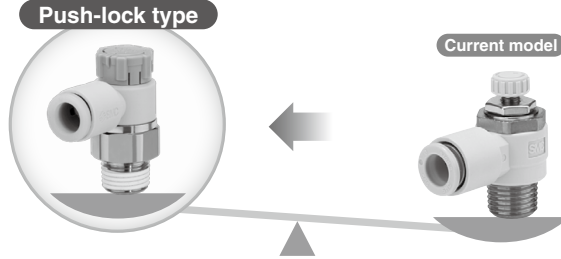

Tubing O.D.	Thread	Part no.	Weight
ø6	1/4	AS22□1F-02-06A	<b>18 g</b>
ø12	1/2	AS42□1F-04-12A	<b>56 g</b>

Tubing O.D.	Thread	Part no.	Weight
ø6	1/4	AS22□1F-02-06	<b>32 g</b>
ø12	1/2	AS42□1F-04-12	<b>101 g</b>

## Face seal adopted for threading

- Improved installability (Reduced tool-tightening after hand-tightening)

### ■ Face seal

At hand-tightening

After tool-tightening

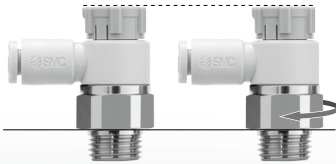

Number of rotations after hand-tightening **1/6 of a rotation or less**

### ■ Sealant

At hand-tightening

After tool-tightening

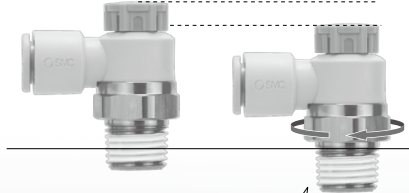

Number of rotations after hand-tightening **2 to 3 rotations**

- Prevention of sealant residue/protrusion

Current sealant type leaves residue and protrudes out from the threading when installing, making it necessary to clear away the residue using an air blower or similar. However, no residue is created when using a face seal.

- Re-piping is possible.

### Face seal

Repeated re-piping some 6 to 10 times is possible due to use of elastic sealant on seating.

### Sealant

Sealant tape is necessary because sealant becomes separated with repeated installation.

## Uniform height

Uneven heights due to thread and needle variations

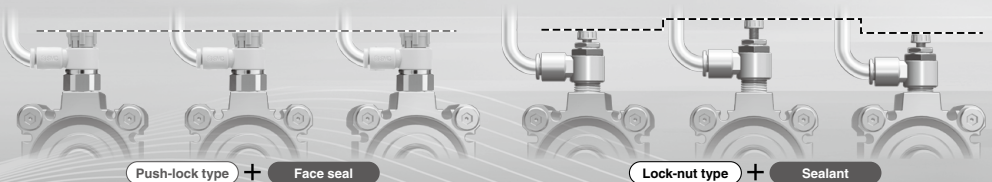

Push-lock type + Face seal

Lock-nut type + Sealant

Series Variations

⊙ Electroless nickel plating type is standardized. ⊙ Stainless steel type is standardized. ⊙ G thread (Face seal) is standardized.

Seal method	Body size	Port size	Applicable tubing O.D.												Metal parts material	Applicable tubing material		
			Metric size						Inch size									
			2	3.2	4	6	8	10	12	16	1/8"	5/32"	1/4"	5/16"			3/8"	1/2"
Gasket seal	1	M5 x 0.8	⊙	⊙	⊙								⊙	⊙	⊙			
		10-32UNF	⊙											⊙	⊙	⊙		
Sealant *1	2	R	1/8															
		1/4																
	3	NPT	1/4	⊙														
		3/8																
Face seal	2	G	1/8															
		1/4																
	3	NPT	1/4	⊙														
		3/8																
Gasket seal	2	R	1/8															
		1/4																
	3	NPT	3/8															
		1/2																
Gasket seal	2	Uni	1/8															
		1/4																
	3	Uni	1/4	⊙														
		3/8																
4	Uni	1/2																
	Uni	1/2																

\*1 "Without sealant" type can be selected as a standard option. \*2 Universal type is not available.

**Restrictor (Made to Order → P.562, 571)**

• Flow control of the air blow and air purge

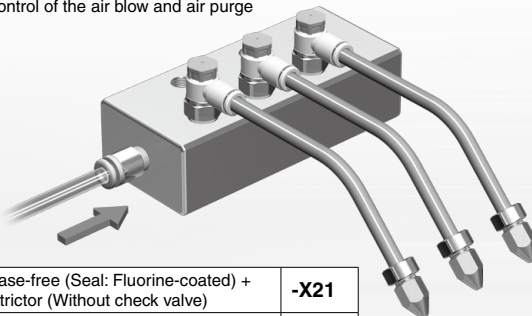

Grease-free (Seal: Fluorine-coated) + Restrictor (Without check valve)	-X21
Restrictor (Without check valve)	-X214

## Easy identification of product type

Series	Release button color			
	Meter-out	Meter-in	Metric	Inch
Brass	Gray	Light blue	Light gray	Orange
Stainless steel	Gray	Light blue	White	White

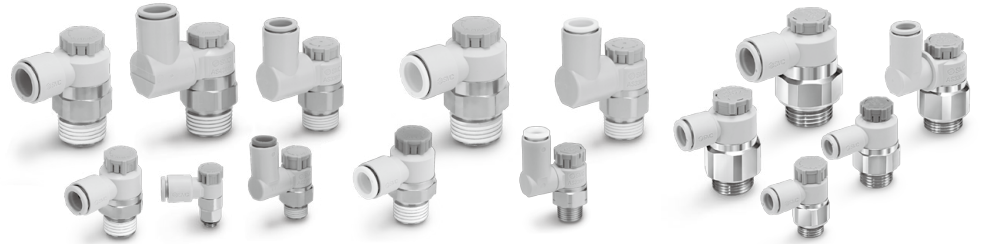

- AS-F
- TMH
- ASD
- AS
- AS-FE
- KE
- AS-FG
- AS-FP
- AS-FM
- AS-D
- AS-T
- ASP
- ASN
- AQ
- ASV
- AK
- VCHC
- ASR
- ASQ

# Speed Controller with One-touch Fitting

Push-lock Type

## Elbow Type/Universal Type

# AS Series



### Model

Model		Port size	Seal method	Applicable tubing O.D.																	
Elbow type	Universal type			Metric size						Inch size											
				2 <sup>Note 2)</sup>	3.2	4	6	8	10	12	16	1/8"	5/32"	1/4"	5/16"	3/8"	1/2"				
AS12□1F-M5□	AS13□1F-M5□	M5 x 0.8	Gasket seal	● <sup>Note 3)</sup>	●	●	●							●	●	●					
AS12□1F-U10/32□	AS13□1F-U10/32□	10-32UNF	Gasket seal	● <sup>Note 3)</sup>	●	●	●							●	●	●					
AS22□1F-□01	AS23□1F-□01	R NPT	Sealant <sup>Note 1)</sup>	1/8			●	●	●	● <sup>Note 3)</sup>						●	●	●			
AS22□1F-□02	AS23□1F-□02			1/4		● <sup>Note 3)</sup>	●	●	●				● <sup>Note 3)</sup>	●	●	●	●	●			
AS32□1F-□02	AS33□1F-□02			1/4			●	●	●	●	●				●	●	●	●	●		
AS32□1F-□03	AS33□1F-□03			3/8			●	●	●	●	●				●	●	●	●	●		
AS42□1F-□04	AS43□1F-□04			1/2							●	●	● <sup>Note 3)</sup>					●	●	●	●

Note 1) "Without sealant" type can be selected as a standard option.

Note 2) Only polyurethane tubing is applicable for ø2.

Note 3) Universal type is not available.

### Specifications

#### Flow Direction Symbols on Body

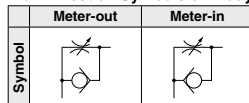

Fluid	Air
Proof pressure	1.5 MPa
Max. operating pressure	1 MPa
Min. operating pressure	0.1 MPa
Ambient and fluid temperature	-5 to 60°C (No freezing)
Applicable tubing material	Nylon, Soft nylon, Polyurethane <sup>Note)</sup> , FEP, PFA

Note) Use caution at the max. operating pressure when using soft nylon or polyurethane tubing. (Refer to pages 464 and 465 for details.)

### Flow Rate and Sonic Conductance

#### Caution

Be sure to read this before handling the products. Refer to back page 50 for Safety Instructions, pages 543 to 546 for Flow Control Equipment Precautions, and pages 573 to 575 for Specific Product Precautions.

Model	AS12□1F-M5□	AS13□1F-M5□	AS22□1F-□01 <sup>Note 3)</sup>	AS23□1F-□01 <sup>Note 3)</sup>	AS22□1F-□02	AS23□1F-□02	AS32□1F	AS33□1F	AS42□1F	AS43□1F					
	Tubing O.D.	Metric size ø2	ø3.2 ø4 ø6	ø3.2	ø4	ø6 ø8 ø10	ø3.2	ø4	ø6	ø8 ø10	ø10 ø12	ø10 ø16			
	Inch size	—	ø1/8" ø1/4" ø5/32"	ø1/8"	ø5/32" ø1/4" ø5/16"	ø1/8"	ø5/32"	—	ø1/4" ø5/16" ø3/8"	ø1/4"	ø5/16" ø3/8"	ø3/8" ø1/2"			
C values: Sonic conductance (dm <sup>3</sup> /s/bar)	Free flow	0.2	0.3	0.4	0.6	0.6	0.7	1.0	1.3	1.5	1.6	1.7	2.5	4.4	4.8
	Controlled flow	0.2	0.3	0.4	0.7	0.8	0.6	0.9	1.3	2.1	2.4	3.3	4.4	4.9	
b values: Critical pressure ratio	Free flow	0.3	0.4	0.2	0.3	0.3	0.3	0.4	0.4	0.3	0.3	0.3	0.3		
	Controlled flow		0.2	0.2	0.3	0.3	0.3	0.3	0.3	0.3	0.3	0.3	0.3		

Note 1) 10-32UNF has the same specification as M5.

Note 2) C and b values are for controlled flow with the needle fully open and free flow with the needle fully closed.

Note 3) The same specifications also apply to the AS-FG series (stainless steel type).

# Speed Controller with One-touch Fitting **AS Series**

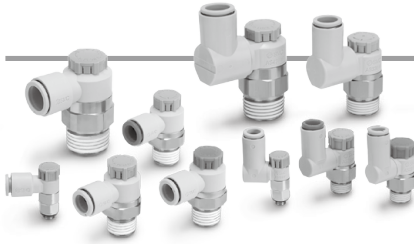

## How to Order

### Applicable tubing O.D. <sup>Note 1)</sup>

Metric size		Inch size	
02	ø2	01	ø1/8"
23	ø3.2 <sup>Note 2)</sup>	03	ø5/32"
04	ø4	07	ø1/4"
06	ø6		

Note 1) For selecting applicable tubing O.D., refer to the "Model" on page 554. Metric size and inch size types can be visually identified by color of the release button.

Metric size: Light gray  
Inch size: Orange

Note 2) Use ø1/8" tube.

### Width across flats (H)

E	8 mm
Nil	9 mm

### Body size

1	M5 x 0.8 10-32UNF
---	----------------------

### Port size

M5	M5 x 0.8
U10/32	10-32UNF

Body size 1

AS 1 2 0 1 F - M5 E - 06 A -

Body size 2/3/4

AS 2 2 0 1 F - 01 - 06 S A -

### Body size

2	1/8, 1/4
3	3/8
4	1/2

### Type

2	Elbow
3	Universal

### Control type <sup>Note)</sup>

0	Meter-out
1	Meter-in

Note) Meter-out and meter-in types can be visually identified by color of the knob.  
Meter-out: Gray  
Meter-in: Light blue

•Made to Order  
Refer to page 562 for details.

•Push-lock type

### Seal method

Nil	Without sealant
S	With sealant

### Applicable tubing O.D. <sup>Note 1)</sup>

Metric size		Inch size	
23	ø3.2 <sup>Note 2)</sup>	01	ø1/8"
04	ø4	03	ø5/32"
06	ø6	07	ø1/4"
08	ø8	09	ø5/16"
10	ø10	11	ø3/8"
12	ø12	13	ø1/2"
16	ø16		

Note 1) For selecting applicable tubing O.D., refer to the "Model" on page 554.

Note 2) Use ø1/8" tube.

### Thread type

Nil	R
N	NPT

### Port size

01	1/8
02	1/4
03	3/8
04	1/2



**Made to Order**  
(For details, refer to page 562.)

Symbol	Specifications
-X12	Lubricant: Vaseline
-X21	Grease-free (Seal: Fluorine-coated) + Restrictor (Without check valve)
-X214	Restrictor (Without check valve)
10-	Clean Series

AS-F

TMH

ASD

AS

AS-FE

KE

AS-FG

AS-FP

AS-FM

AS-D

AS-T

ASP

ASN

AQ

ASV

AK

VCHC

ASR

ASQ

## Needle Valve/Flow Rate Characteristics

AS1201F-M5□, AS1211F-M5□  
AS1301F-M5□, AS1311F-M5□

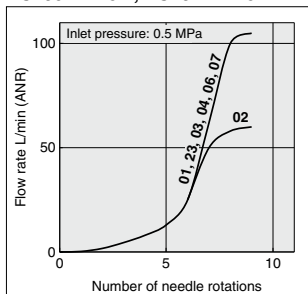

Note) -U10/32 has the same specification as M5.

AS2201F-01, AS2211F-01  
AS2301F-01, AS2311F-01

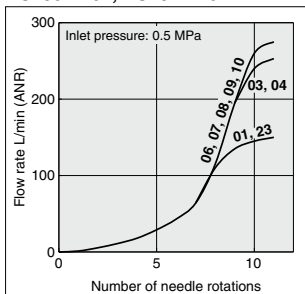

AS2201F-02, AS2211F-02  
AS2301F-02, AS2311F-02

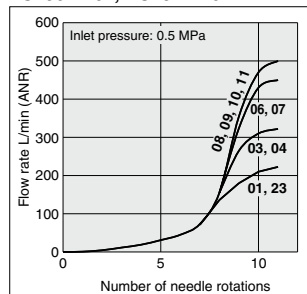

AS3201F, AS3211F  
AS3301F, AS3311F

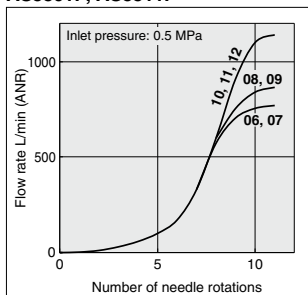

AS4201F, AS4211F  
AS4301F, AS4311F

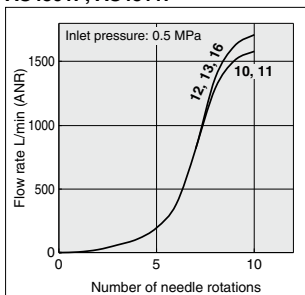

Note) The numbers above the flow rate characteristic curves in the charts show the applicable tubing outside diameter as defined by the product number.



**Construction**

**Elbow type**

Seal method: Gasket seal  
For M5, 10-32UNF

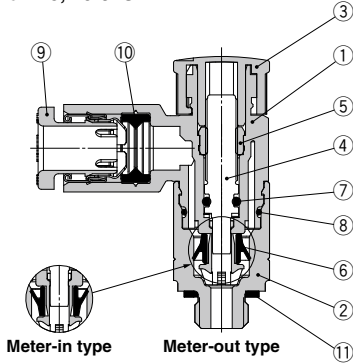

Seal method: Sealant  
For R, NPT thread

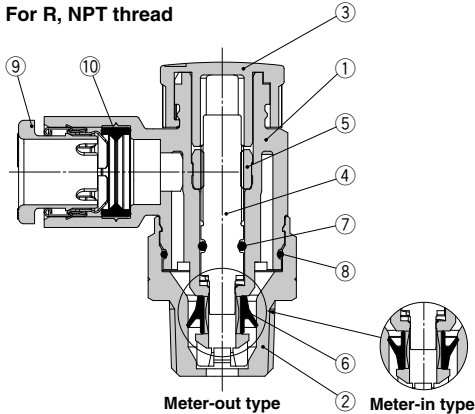

**Component Parts**

No.	Description	Material	Note
1	Body A	PBT	
2	Body B	Brass	Electroless nickel plating
3	Knob	POM	
4	Needle	PBT	
5	Needle guide	Brass	Electroless nickel plating
6	U-seal	HNBR	
7	O-ring	NBR	
8	O-ring	NBR	
9	Cassette	—	
10	Seal	NBR	
11	Gasket	NBR/Stainless steel	

**Universal type**

Seal method: Gasket seal  
For M5, 10-32UNF

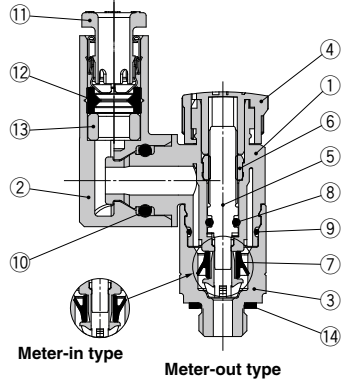

Seal method: Sealant  
For R, NPT thread

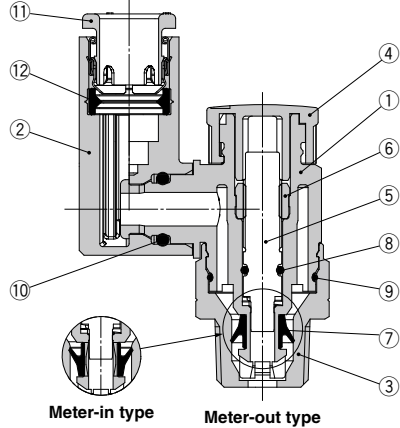

**Component Parts**

No.	Description	Material	Note
1	Body A	PBT	
2	Elbow body	PBT	
3	Body B	Brass	Electroless nickel plating
4	Knob	POM	
5	Needle	PBT	
6	Needle guide	Brass	Electroless nickel plating
7	U-seal	HNBR	
8	O-ring	NBR	
9	O-ring	NBR	
10	O-ring	NBR	
11	Cassette	—	
12	Seal	NBR	
13	Spacer <sup>(Note)</sup>	PBT	
14	Gasket	NBR/Stainless steel	

Note) Spacer is included only for the applicable tubing O.D.  $\phi 3.2$ ,  $\phi 1/8"$ ,  $\phi 4$ ,  $\phi 5/32"$  and  $\phi 6$ .

AS-F
TMH
ASD
AS
AS-FE
KE
AS-FG
AS-FP
AS-FM
AS-D
AS-T
ASP
ASN
AQ
ASV
AK
VCHC
ASR
ASQ

## Dimensions/ Elbow type

Seal method: Gasket seal  
For M5, 10-32UNF

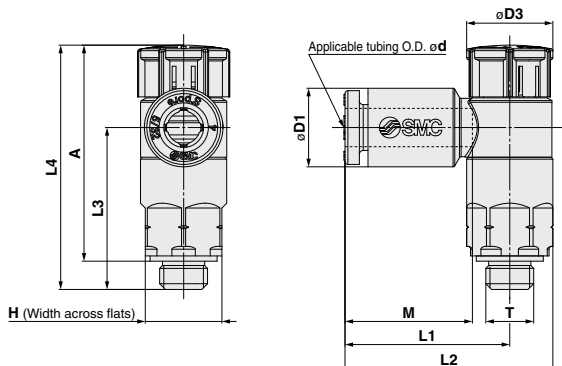

### Metric Size

Model	d	T	H <sup>Note 1)</sup>	D1	D3	L1	L2	L3	L4 <sup>Note 2)</sup>		A <sup>Note 3)</sup>		M	Weight [g]				
									Unlocked	Locked	Unlocked	Locked						
AS12□1F-M5E-02A	2	M5 x 0.8 10/32UNF	8 (9)	5.8	9.4	15.8	20.3	16.9	26.5	25.4	23.5	22.4	11.9	5				
AS12□1F-U10/32E-02A																		
AS12□1F-M5E-23A	3.2			7.2		17.2	21.7	16.5							13.3	6		
AS12□1F-U10/32E-23A																		
AS12□1F-M5E-04A	4			8.2		18.6	23.1	16.5										
AS12□1F-U10/32E-04A																		
AS12□1F-M5E-06A	6	10.4																
AS12□1F-U10/32E-06A																		

Note 1) The value in ( ) indicates that the dimension for the width across flats is 9 mm.

Note 2) Reference dimensions

Note 3) Reference dimensions of threads after installation

### Inch Size

Model	d	T	H <sup>Note 1)</sup>	D1	D3	L1	L2	L3	L4 <sup>Note 2)</sup>		A <sup>Note 3)</sup>		M	Weight [g]		
									Unlocked	Locked	Unlocked	Locked				
AS12□1F-M5E-01A	1/8"	M5 x 0.8 10/32UNF	8 (9)	7.2	9.4	17.2	21.7	16.9	26.5	25.4	23.5	22.4	13.3	5		
AS12□1F-U10/32E-01A																
AS12□1F-M5E-03A	5/32"			8.2		18.6	23.1	16.5								
AS12□1F-U10/32E-03A																
AS12□1F-M5E-07A	1/4"			11.2												
AS12□1F-U10/32E-07A																

Note 1) The value in ( ) indicates that the dimension for the width across flats is 9 mm.

Note 2) Reference dimensions

Note 3) Reference dimensions of threads after installation

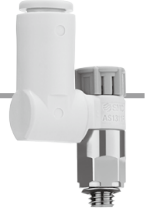

Dimensions/ **Universal type**

Seal method: Gasket seal  
For M5, 10-32UNF

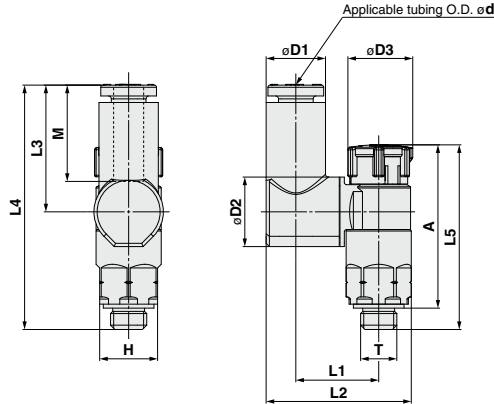

Metric Size

Model	d	T	H <sup>Note 1)</sup>	D1	D2	D3	L1	L2	L3	L4	L5 <sup>Note 2)</sup>		A <sup>Note 3)</sup>		M	Weight [g]
											Unlocked	Locked	Unlocked	Locked		
AS13□1F-M5E-23A	3.2	M5 x 0.8 10/32UNF	8 (9)	7.2	9.6	9.4	11.6	19.4	17.5	33.8	26.5	25.4	23.5	22.4	13.3	6
AS13□1F-U10/32E-23A																
AS13□1F-M5E-04A	4						8.2			11.5						
AS13□1F-U10/32E-04A																
AS13□1F-M5E-06A	6			10.4				20.9	20.4	36.6						
AS13□1F-U10/32E-06A																

Note 1) The value in ( ) indicates that the dimension for the width across flats is 9 mm.

Note 2) Reference dimensions

Note 3) Reference dimensions of threads after installation

Inch Size

Model	d	T	H <sup>Note 1)</sup>	D1	D2	D3	L1	L2	L3	L4	L5 <sup>Note 2)</sup>		A <sup>Note 3)</sup>		M	Weight [g]
											Unlocked	Locked	Unlocked	Locked		
AS13□1F-M5E-01A	1/8"	M5 x 0.8 10/32UNF	8 (9)	7.2	9.6	9.4	11.6	19.4	17.5	33.8	26.5	25.4	23.5	22.4	13.3	6
AS13□1F-U10/32E-01A																
AS13□1F-M5E-03A	5/32"						8.2			11.5						
AS13□1F-U10/32E-03A																
AS13□1F-M5E-07A	1/4"			11.2				21.3	20.2	36.5						
AS13□1F-U10/32E-07A																

Note 1) The value in ( ) indicates that the dimension for the width across flats is 9 mm.

Note 2) Reference dimensions

Note 3) Reference dimensions of threads after installation

- AS-F
- TMH
- ASD
- AS
- AS-FE
- KE
- AS-FG
- AS-FP
- AS-FM
- AS-D
- AS-T
- ASP
- ASN
- AQ
- ASV
- AK
- VCHC
- ASR
- ASQ

## Dimensions/ Elbow type

Seal method: Sealant  
For R, NPT thread

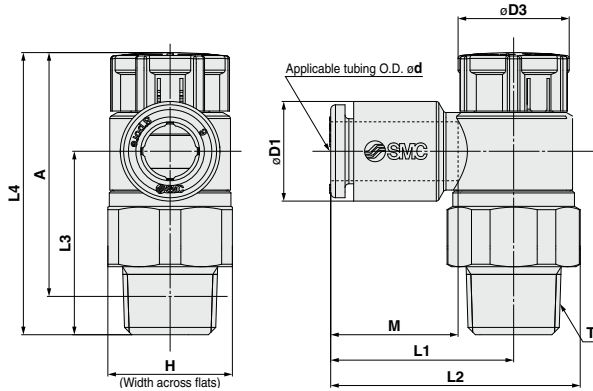

### Metric Size

Model	d	T	H	D1	D3	L1	L2	L3	L4 <sup>Note 1)</sup>		A <sup>Note 2)</sup>		M	Weight [g]
									Unlocked	Locked	Unlocked	Locked		
AS22□1F-01-23(S)A	3.2	1/8	13 (12.7)	7.2	12	19.1	26.2	19.1	30.6	29.2	27.5	26.1	13.3	9 (9)
AS22□1F-01-04(S)A	4			8.2										10 (9)
AS22□1F-01-06(S)A	6			10.4										11 (10)
AS22□1F-01-08(S)A	8			13.2										12 (11)
AS22□1F-01-10(S)A	10	15.9	15.9	15.6	12 (11)									
AS22□1F-02-23(S)A	3.2	1/4	17 (17.5)	7.2	13	20.9	30.2 (30.3)	22.6	36.6	35	31.1	29.5	13.3	18 (19)
AS22□1F-02-04(S)A	4			8.2										18 (19)
AS22□1F-02-06(S)A	6			10.4										19 (20)
AS22□1F-02-08(S)A	8			13.2										20 (21)
AS22□1F-02-10(S)A	10	15.9	26.9	20 (21)										
AS32□1F-02-06(S)A	6	1/4	19	10.4	16.6	21.8	32.1	36.4	50	48.4	44.5	42.9	13.3	40 (40)
AS32□1F-02-08(S)A	8			13.2										41 (41)
AS32□1F-02-10(S)A	10			15.9										42 (42)
AS32□1F-02-12(S)A	12			18.5										43 (43)
AS32□1F-03-06(S)A	6	3/8	19	10.4	16.6	21.8	32.1	28.7	42.3	40.7	37.1	35.5	13.3	31 (32)
AS32□1F-03-08(S)A	8			13.2										32 (33)
AS32□1F-03-10(S)A	10			15.9										33 (33)
AS32□1F-03-12(S)A	12			18.5										34 (35)
AS42□1F-04-10(S)A	10	1/2	24 (23.8)	15.9	18.8	27.4	40.3 (40.2)	36.2	50.8	49.2	43.7	42.1	15.6	54 (53)
AS42□1F-04-12(S)A	12			18.5										55 (55)
AS42□1F-04-14(S)A	14			23.8										60 (59)
AS42□1F-04-16(S)A	16			34.8										60 (59)

Note 1) Reference dimensions Note 2) Reference dimensions of threads after installation Note 3) The values in ( ) are for NPT thread.

### Inch Size

Model	d	T	H	D1	D3	L1	L2	L3	L4 <sup>Note 1)</sup>		A <sup>Note 2)</sup>		M	Weight [g]
									Unlocked	Locked	Unlocked	Locked		
AS22□1F-01-01(S)A	1/8"	1/8	13 (12.7)	7.2	12	19.1	26.2	19.1	30.6	29.2	27.5	26.1	13.3	9 (9)
AS22□1F-01-03(S)A	5/32"			8.2										10 (9)
AS22□1F-01-07(S)A	1/4"			11.2										11 (10)
AS22□1F-01-09(S)A	5/16"			13.2										12 (11)
AS22□1F-02-01(S)A	1/8"	1/4	17 (17.5)	7.2	13	20.9	30.2 (30.3)	22.6	36.6	35	31.1	29.5	13.3	18 (19)
AS22□1F-02-03(S)A	5/32"			8.2										19 (19)
AS22□1F-02-07(S)A	1/4"			11.2										20 (21)
AS22□1F-02-09(S)A	5/16"			13.2										21 (21)
AS22□1F-02-11(S)A	3/8"	15.5	26.4	20 (21)										
AS32□1F-02-07(S)A	1/4"	1/4	19	11.2	16.6	21.8	32.1	36.4	50	48.4	44.5	42.9	13.3	40 (40)
AS32□1F-02-09(S)A	5/16"			13.2										41 (41)
AS32□1F-02-11(S)A	3/8"			15.5										42 (42)
AS32□1F-03-07(S)A	1/4"			11.2										43 (43)
AS32□1F-03-09(S)A	5/16"	3/8	19	13.2	16.6	22.7	33	28.7	42.3	40.7	37.1	35.5	15.6	54 (53)
AS32□1F-03-11(S)A	3/8"			15.5										55 (55)
AS42□1F-04-11(S)A	1/2"			24 (23.8)										60 (59)
AS42□1F-04-13(S)A	3/8"			19.3										60 (59)

Note 1) Reference dimensions Note 2) Reference dimensions of threads after installation Note 3) The values in ( ) are for NPT thread.



Dimensions/ **Universal type**

Seal method: Sealant  
For R, NPT thread

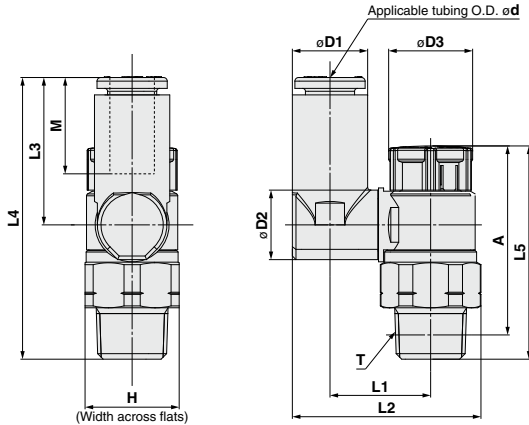

Metric Size

Model	d	T	H	D1	D2	D3	L1	L2	L3	L4	L5 Note 1)		A Note 2)		M	[mm]								
											Unlocked	Locked	Unlocked	Locked		Weight [g]								
AS23□1F-01-23(S)A	3.2	1/8	13 (12.7)	7.2	9.6	12	13.3	24	17.5	36	30.6	29.2	27.5	26.1	13.3	10 (10)								
AS23□1F-01-04(S)A	4			8.2			13.9	25.1								11 (10)								
AS23□1F-01-06(S)A	6			10.4	16.4		26.2	12 (12)																
AS23□1F-01-08(S)A	8			13.2	16.4		30.1	14.2 (12)																
AS23□1F-02-04(S)A	4	1/4	17 (17.5)	8.2	12.9	13	16.5	29.9 (30)	17.5	40.1	36.6	35	31.1	29.5	13.3	19 (20)								
AS23□1F-02-06(S)A	6			11.2			19	33.8 (33.9)								21.4	43.9	21 (22)						
AS23□1F-02-08(S)A	8			13.2	19		34.9 (35)	23.5	46	14.2 (22)														
AS23□1F-02-10(S)A	10			15.9	20.9		38.1 (38.2)	24.7	47.3	15.6 (23)														
AS23□1F-02-06(S)A	6			11.2	12.9	16.6	20.2	36	21.4	57.8						13.3	42 (42)							
AS33□1F-02-08(S)A	8			13.2	16.6	23	37.1	23.5	59.9	14.2						43 (43)								
AS33□1F-02-10(S)A	10	15.9	23	41.2	26.1	62.5	15.6	46 (46)																
AS33□1F-02-12(S)A	12	18.5	17.4	23	42.5	28.3	64.7	17	48 (48)															
AS33□1F-03-06(S)A	6	3/8	19	11.2	12.9	16.6	20.2	36	21.4	50.1	42.3	40.7	37.1	35.5	13.3	34 (35)								
AS33□1F-03-08(S)A	8			13.2			20.2	37.1								23.5	52.2	14.2	35 (36)					
AS33□1F-03-10(S)A	10			15.9	23		41.2	26.1	54.8	15.6						38 (39)								
AS33□1F-03-12(S)A	12			18.5	23		42.5	28.3	57	17						40 (41)								
AS43□1F-04-10(S)A	10			1/2	24 (23.8)	15.9	17.4	18.8	25.6	46.4 (46.3)						26.1	61.2	50.8	49.2	43.7	42.1	15.6	61 (69)	
AS43□1F-04-12(S)A	12					18.5			21	26.2													48.3 (48.2)	28.3

Note 1) Reference dimensions Note 2) Reference dimensions of threads after installation Note 3) The values in ( ) are for NPT thread.

Inch Size

Model	d	T	H	D1	D2	D3	L1	L2	L3	L4	L5 Note 1)		A Note 2)		M	[mm]						
											Unlocked	Locked	Unlocked	Locked		Weight [g]						
AS23□1F-01-01(S)A	1/8"	1/8	13 (12.7)	7.2	9.6	12	13.3	24	17.5	36	30.6	29.2	27.5	26.1	13.3	10 (10)						
AS23□1F-01-03(S)A	5/32"			8.2			13.9	25.1								11 (10)						
AS23□1F-01-07(S)A	1/4"			11.2	16.4		29.1	20.2	38.7	12 (12)												
AS23□1F-01-09(S)A	5/16"			13.2	16.4		30.1	21.5	40	14.2 (12)												
AS23□1F-02-03(S)A	5/32"	1/4	17 (17.5)	8.2	12.9	13	16.5	29.9 (30)	17.5	40.1	36.6	35	31.1	29.5	13.3	19 (20)						
AS23□1F-02-07(S)A	1/4"			11.2			19	33.8 (33.9)								21.4	43.9	21 (22)				
AS23□1F-02-09(S)A	5/16"			13.2	19		34.9 (35)	23.5	46	14.2 (22)												
AS23□1F-02-11(S)A	3/8"			15.9	20.9		38.1 (38.2)	24.7	47.3	15.6 (23)												
AS33□1F-02-07(S)A	1/4"			11.2	12.9	16.6	20.2	36	21.4	57.8						13.3	42 (42)					
AS33□1F-02-09(S)A	5/16"			13.2	16.6	23	37.1	23.5	59.9	14.2						43 (43)						
AS33□1F-02-11(S)A	3/8"	15.9	17.4	23	41.2	26.1	62.5	15.6	46 (46)													
AS33□1F-03-07(S)A	1/4"	3/8	19	11.2	12.9	16.6	20.2	36	21.4	50.1	42.3	40.7	37.1	35.5	13.3	34 (35)						
AS33□1F-03-09(S)A	5/16"			13.2			20.2	37.1								23.5	52.2	14.2	35 (36)			
AS33□1F-03-11(S)A	3/8"			15.9	23		41.2	26.1	54.8	15.6						38 (39)						
AS43□1F-04-11(S)A	3/8"			18.5	23		42.5	28.3	57	17						40 (41)						
AS43□1F-04-13(S)A	1/2"			24 (23.8)	17.4	18.8	25.6	46.4 (46.3)	26.1	61.2						50.8	49.2	43.7	42.1	15.6	61 (69)	
AS43□1F-04-13(S)A	1/2"						18.5	21													26.2	48.3 (48.2)

Note 1) Reference dimensions Note 2) Reference dimensions of threads after installation Note 3) The values in ( ) are for NPT thread.

# AS Series

## Made to Order

Please contact SMC for detailed dimensions, specifications and lead times.

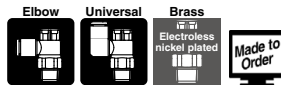

### 1 Lubricant: Vaseline

-X12

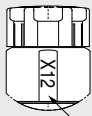

Laser printing

Example) AS2201F-01-04SA-X12

### 2 Grease-free (Seal: Fluorine-coated) + Restrictor (Without check valve)

-X21

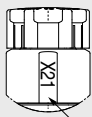

Laser printing

Example) AS2201F-01-04SA-X21

Note 1) Not particle-free

Note 2) This product is a restrictor without a check valve (no control direction). Be aware that all part numbers are for a meter-out type; there is no part number for a meter-in type.

Note 3) Only the needle and O-ring are fluorine-coated.

### 3 Restrictor (Without check valve)

-X214

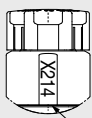

Laser printing

Example) AS2201F-01-04SA-X214

Note) This product is a restrictor without a check valve (no control direction). Be aware that all part numbers are for a meter-out type; there is no part number for a meter-in type.

### 4 Clean Series

10-

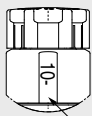

Laser printing

Example) 10-AS2201F-01-04SA

Note 1) Fluorine grease is used.

Note 2) The cleanliness class (ISO class) is 5.

Note 3) Excluding G thread type.

<b>AS-F</b>
<b>TMH</b>
<b>ASD</b>
<b>AS</b>
<b>AS-FE</b>
<b>KE</b>
<b>AS-FG</b>
<b>AS-FP</b>
<b>AS-FM</b>
<b>AS-D</b>
<b>AS-T</b>
<b>ASP</b>
<b>ASN</b>
<b>AQ</b>
<b>ASV</b>
<b>AK</b>
<b>VCHC</b>
<b>ASR</b>
<b>ASQ</b>

# Speed Controller with One-touch Fitting

Push-lock Type Face Seal

## Elbow Type/Universal Type

# AS Series



### Model

Model		Port size	Seal method	Applicable tubing O.D.																		
Elbow type	Universal type			Metric size						Inch size												
				3.2	4	6	8	10	12	16	1/8"	5/32"	1/4"	5/16"	3/8"	1/2"						
AS22□1F-G01	AS23□1F-G01	G	Face seal	●	●	●	●	● <sup>Note)</sup>														
AS22□1F-G02	AS23□1F-G02			1/8	● <sup>Note)</sup>	●	●	●	●													
AS32□1F-G02	AS33□1F-G02			1/4			●	●	●	●												
AS32□1F-G03	AS33□1F-G03			3/8			●	●	●	●												
AS42□1F-G04	AS43□1F-G04			1/2						●	●	● <sup>Note)</sup>										
AS22□1F-01-□PA	—	R NPT	Face seal	1/8	●	●	●	●	●			●	●	●	●							
AS22□1F-02-□PA	—			1/4	●	●	●	●	●			●	●	●	●	●						
AS32□1F-03-□PA	—			3/8			●	●	●	●				●	●	●	●					
AS42□1F-04-□PA	—			1/2						●	●						●	●				

Note) Universal type is not available.

### Specifications

#### Flow Direction Symbols on Body

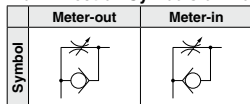

Fluid	Air
Proof pressure	1.5 MPa
Max. operating pressure	1 MPa
Min. operating pressure	0.1 MPa
Ambient and fluid temperature	-5 to 60°C (No freezing)
Applicable tubing material	Nylon, Soft nylon, Polyurethane <sup>Note)</sup> , FEP, PFA

Note) Use caution at the max. operating pressure when using soft nylon or polyurethane tubing.  
(Refer to pages 464 and 465 for details.)

### Flow Rate and Sonic Conductance

### ⚠ Caution

Be sure to read this before handling the products. Refer to back page 50 for Safety Instructions, pages 543 to 546 for Flow Control Equipment Precautions, and pages 573 to 575 for Specific Product Precautions.

Model	AS2□1F-G01 AS22□1F-01-□PA			AS2□1F-G02 AS22□1F-02-□PA				AS3□1F-G02/03 AS32□1F-03-□PA			AS4□1F-G04 AS42□1F-04-□PA		
	Metric size	ø3.2	ø4	ø6 ø8 ø10	ø3.2	ø4	ø6 ø8 ø10	ø6	ø8	ø10 ø12	ø10	ø12 ø16	
Tubing O.D.	Note 2) Inch size	ø1/8"	ø5/32"	ø1/4" ø5/16"	ø1/8"	ø5/32"	—	ø1/4" ø5/16" ø3/8"	ø1/4"	ø5/16"	ø3/8"	ø3/8" ø1/2"	
	C values: Sonic conductance (dm <sup>3</sup> /(s·bar))	Free flow	0.4	0.6	0.6	0.7	1.0	1.3	1.5	1.6	1.7	2.5	4.4
b values: Critical pressure ratio	Controlled flow	0.4	0.7	0.8	0.6	0.9	1.3	2.1	2.4	3.3	4.4	4.9	
	Free flow	0.2	0.3	0.3	0.3	0.4	0.4	0.3	0.3	0.3	0.3	0.3	
	Controlled flow	0.2	0.3	0.3	0.3	0.3	0.3	0.3	0.3	0.3	0.3	0.3	

Note 1) C and b values are for controlled flow with the needle fully open and free flow with the needle fully closed.

Note 2) G thread is not available.





\* Only G thread

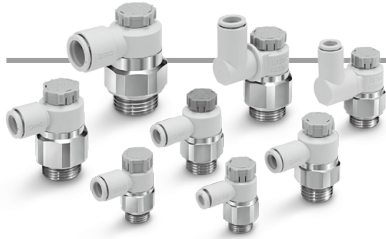

How to Order

**Type**

2	Elbow
3	Universal

**Thread type**

G	G
---	---

**G thread**

**R, NPT thread**

**Body size**

2	1/8, 1/4
3	3/8
4	1/2

**Type**

2	Elbow
---	-------

**Control type**

0	Meter-out
1	Meter-in

**Thread type**

Nil	R
N	NPT

**Port size**

01	1/8
02	1/4
03	3/8
04	1/2

**Seal method**

P	Face seal
---	-----------

**Applicable tubing O.D.** Note 1)

Metric size	Inch size <small>Note 3)</small>
23	01 $\phi$ 1/8"
04	03 $\phi$ 5/32"
06	07 $\phi$ 1/4"
08	08 $\phi$ 5/16"
10	11 $\phi$ 3/8"
12	13 $\phi$ 1/2"
16	$\phi$ 16 <small>Note 4)</small>

**Made to Order**  
For details, refer to page 571.

**Push-lock type**

**Caution**

Cylinders with a level bearing surface are suitable for the R thread or NPT thread face seal type. The R-shaped bearing surface of CG1 cylinders is not suitable.

**Made to Order**  
(For details, refer to page 571.)

Symbol	Specifications
-X12	Lubricant: Vaseline
-X21	Grease-free (Seal: Fluorine-coated) + Restrictor (Without check valve)
-X214	Restrictor (Without check valve)
10-	Clean Series

AS-F

TMH

ASD

AS

AS-FE

KE

AS-FG

AS-FP

AS-FM

AS-D

AS-T

ASP

ASN

AQ

ASV

AK

VCHC

ASR

ASQ

## Needle Valve/Flow Rate Characteristics

AS2201F-G01-□, AS2211F-G01-□  
 AS2301F-G01-□, AS2311F-G01-□  
 AS2201F-01-□PA, AS2211F-01-□PA

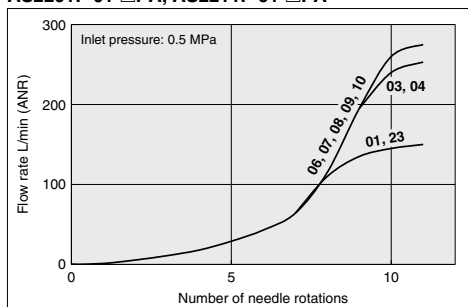

AS2201F-G02-□, AS2211F-G02-□  
 AS2301F-G02-□, AS2311F-G02-□  
 AS2201F-02-□PA, AS2211F-02-□PA

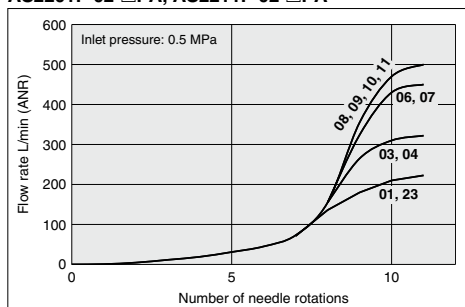

AS3201F-G02/03-□, AS3211F-G02/03-□  
 AS3301F-G02/03-□, AS3311F-G02/03-□  
 AS3201F-03-□PA, AS3211F-03-□PA

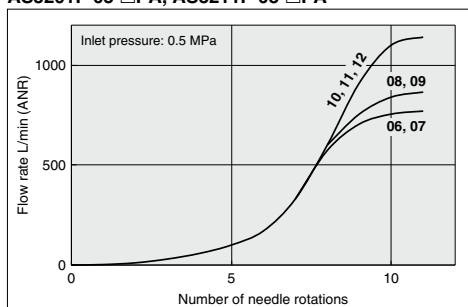

AS4201F-G04-□, AS4211F-G04-□  
 AS4301F-G04-□, AS4311F-G04-□  
 AS4201F-04-□PA, AS4211F-04-□PA

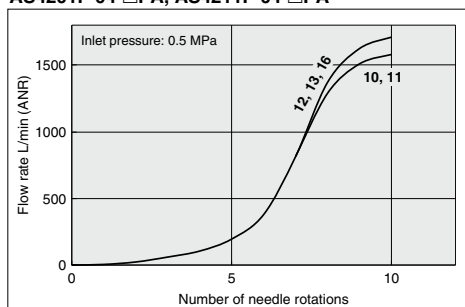

Note) The numbers above the flow rate characteristic curves in the charts show the applicable tubing outside diameter as defined by the product number.

## Construction

### Elbow type

Seal method: Face seal  
For G, R, NPT thread

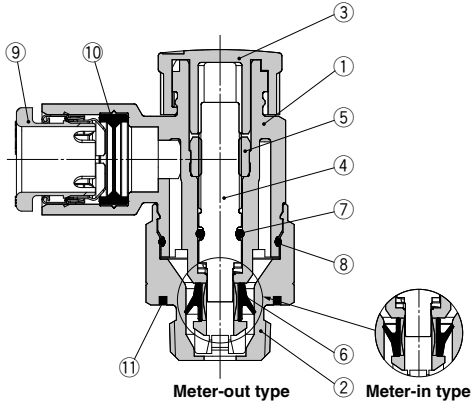

### Component Parts

No.	Description	Material	Note
1	Body A	PBT	
2	Body B	Brass	Electroless nickel plating
3	Knob	POM	
4	Needle	PBT	
5	Needle guide	Brass	Electroless nickel plating
6	U-seal	HNBR	
7	O-ring	NBR	
8	O-ring	NBR	
9	Cassette	—	
10	Seal	NBR	
11	Seal	NBR	

### Universal type

Seal method: Face seal  
For G thread

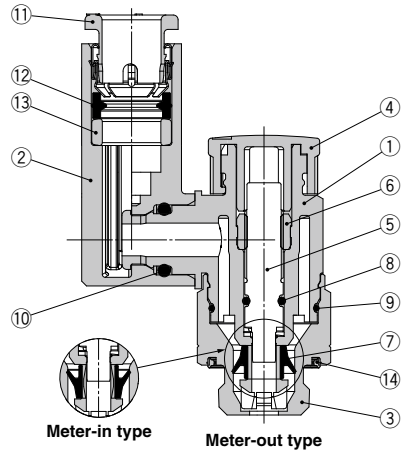

### Component Parts

No.	Description	Material	Note
1	Body A	PBT	
2	Elbow body	PBT	
3	Body B	Stainless steel	
4	Knob	POM	
5	Needle	PBT	
6	Needle guide	Stainless steel	
7	U-seal	HNBR	
8	O-ring	NBR	
9	O-ring	NBR	
10	O-ring	NBR	
11	Cassette	—	
12	Seal	NBR	
13	Spacer	PBT <sup>Note)</sup>	
14	Seal	NBR	

Note) Spacer is included only for the applicable tubing O.D.  $\phi 3.2$ ,  $\phi 1/8$ " ,  $\phi 4$ ,  $\phi 5/32$ " and  $\phi 6$ .

AS-F

TMH

ASD

AS

AS-FE

KE

AS-FG

AS-FP

AS-FM

AS-D

AS-T

ASP

ASN

AQ

ASV

AK

VCHC

ASR

ASQ

## Dimensions/ Elbow type

Seal method: Face seal  
For G thread

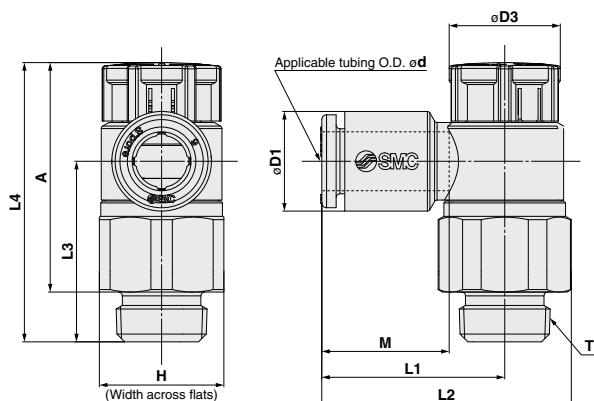

### Metric Size

[mm]

Model	d	T	H	D1	D3	L1	L2	L3	L4		A		M	Weight [g]			
									Unlocked	Locked	Unlocked	Locked					
AS22□1F-G01-23A	3.2	1/8	13	7.2	12	19.1	26.2	18.8	30.3	28.9	24.8	23.4	13.3	10			
AS22□1F-G01-04A	4			8.2													
AS22□1F-G01-06A	6			10.4													
AS22□1F-G01-08A	8			13.2											22.4	29.5	
AS22□1F-G01-10A	10	15.9	25.3	32.4													
AS22□1F-G02-23A	3.2	1/4	17	7.2	13	23.4	32.7	22.6	36.6	35	30.1	28.5	13.3	21			
AS22□1F-G02-04A	4			8.2											20.9	30.2	
AS22□1F-G02-06A	6			10.4											23.4	32.7	
AS22□1F-G02-08A	8			13.2											23.9	33.2	
AS22□1F-G02-10A	10	15.9	26.9	36.2													
AS32□1F-G02-06A	6	1/4	21	10.4	16.6	21.8	33	36.4	50	48.4	43.5	41.9	13.3	50			
AS32□1F-G02-08A	8			13.2											22.7	33.9	
AS32□1F-G02-10A	10			15.9											26.7	37.9	35.7
AS32□1F-G02-12A	12			18.5											29.7	40.9	34.5
AS32□1F-G03-06A	6	3/8	21	10.4	16.6	21.8	33	28.7	42.3	40.7	34.8	33.2	13.3	38			
AS32□1F-G03-08A	8			13.2											22.7	33.9	
AS32□1F-G03-10A	10			15.9											26.7	37.9	28
AS32□1F-G03-12A	12			18.5											29.7	40.9	26.8
AS42□1F-G04-10A	10	1/2	27	15.9	18.8	30.8	45.2	35.1	50.8	49.2	41.8	40.2	15.6	72			
AS42□1F-G04-12A	12			18.5											27.4	41.8	36.2
AS42□1F-G04-14A	14			20.7											29.7	44.1	34.5
AS42□1F-G04-16A	16			23.8											34.8	49.2	32.7

Dimensions/ **Universal type**

Seal method: Face seal

For G thread

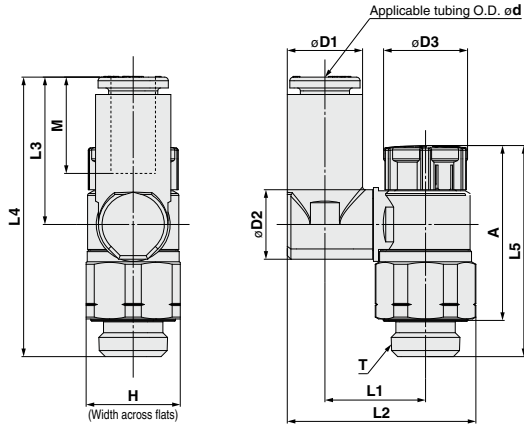

## Metric Size

Model	d	T	H	D1	D2	D3	L1	L2	L3	L4	L5		A		M	Weight [g]
											Unlocked	Locked	Unlocked	Locked		
AS23□1F-G01-23A	3.2	1/8	13	7.2	9.6	12	13.3	24.0	17.5	35.7	30.3	28.9	24.8	23.4	13.3	10
AS23□1F-G01-04A	4			8.2			13.9	25.1								20.4
AS23□1F-G01-06A	6			10.4	16.4		30.1	21.5	39.7	11						
AS23□1F-G01-08A	8			13.2	10.2		16.4	30.1	21.5	39.7					14.2	12
AS23□1F-G02-04A	4	1/4	17	8.2	12.9	13	16.5	29.9	17.5	40.1	36.6	35	30.1	28.5	13.3	22
AS23□1F-G02-06A	6			10.4			33.8	21.4	43.9	24						
AS23□1F-G02-08A	8			13.2	34.9		23.5	46.0	25							
AS23□1F-G02-10A	10			15.9			20.9	38.1	24.7	47.3					15.6	26
AS33□1F-G02-06A	6	1/4	21	10.4	12.9	16.6	20.2	36.6	21.4	57.8	50	48.4	43.5	41.9	13.3	51
AS33□1F-G02-08A	8			13.2			38.0	23.5	59.9	52						
AS33□1F-G02-10A	10			15.9	42.2		26.1	58.0	55							
AS33□1F-G02-12A	12			18.5	17.4		23	43.5	28.3	59.9					17	57
AS33□1F-G03-06A	6	3/8	21	10.4	12.9	16.6	20.2	36.6	21.4	50.1	42.3	40.7	34.8	33.2	13.3	41
AS33□1F-G03-08A	8			13.2			38.0	23.5	52.2	42						
AS33□1F-G03-10A	10			15.9	42.2		26.1	50.3	46							
AS33□1F-G03-12A	12			18.5	17.4		23	43.5	28.3	52.2					17	47
AS43□1F-G04-10A	10	1/2	27	15.9	17.4	18.8	25.6	47.9	26.1	61.2	50.8	49.2	41.8	40.2	15.6	78
AS43□1F-G04-12A	12			18.5	21		26.2	49.8	28.3	63.4						17



AS-F

TMH

ASD

AS

AS-FE

KE

AS-FG

AS-FP

AS-FM

AS-D

AS-T

ASP

ASN

AQ

ASV

AK

VCHC

ASR

ASQ

## Dimensions/ Elbow type

Seal method: Face seal  
For R, NPT thread

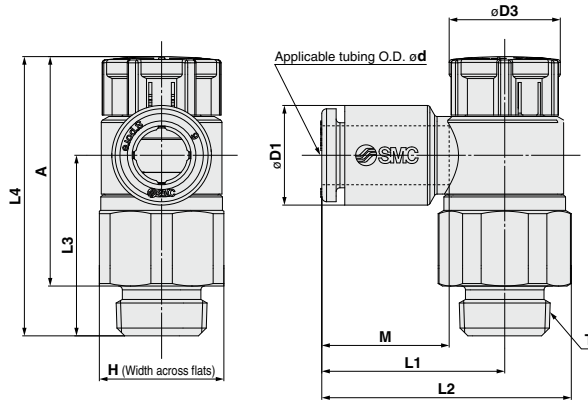

### Metric Size

Model	d	T	H	D1	D3	L1	L2	L3	L4		A		M	Weight [g]
									Unlocked	Locked	Unlocked	Locked		
AS22□1F-01-23PA	3.2	1/8	13 (12.7)	7.2	12	19.1	26.2	18.8	30.3	28.9	25.1 (24.9)	23.7 (23.5)	13.3	10 (9)
AS22□1F-01-04PA	4			8.2										
AS22□1F-01-06PA	6			10.4										
AS22□1F-01-08PA	8			13.2		22.4	29.5						14.2	11 (10)
AS22□1F-01-10PA	10			15.9		25.3	32.4						15.6	12 (11)
AS22□1F-02-23PA	3.2	1/4	17 (17.5)	7.2	13	20.9	30.2 (30.3)	22.6	36.6	35	29 (28.5)	27.4 (26.9)	13.3	19 (20)
AS22□1F-02-04PA	4			8.2										
AS22□1F-02-06PA	6			10.4										
AS22□1F-02-08PA	8			13.2		23.4	32.7 (32.8)						14.2	20 (21)
AS22□1F-02-10PA	10			15.9		23.9	33.2 (33.3)						15.6	21 (22)
AS22□1F-03-06PA	6	3/8	21 (21.7)	10.4	16.6	21.8	33 (33.4)	28.7	42.3	40.7	34.7 (34.2)	33.1 (32.6)	13.3	37 (39)
AS32□1F-03-08PA	8			13.2										
AS32□1F-03-10PA	10			15.9										
AS32□1F-03-12PA	12			18.5		22.7	33.9 (34.3)						14.2	38 (40)
AS32□1F-03-14PA	14			21.8		26.7	37.9 (38.3)	28					15.6	39 (41)
AS42□1F-04-10PA	10	1/2	27 (28.6)	15.9	18.8	27.4	41.8 (42.6)	36.2	50.8	49.2	40.4	38.8	15.6	66 (72)
AS42□1F-04-12PA	12			18.5		30.8	45.2 (46)	35.1						

Note) The values in ( ) are for NPT thread.

### Inch Size

Model	d	T	H	D1	D3	L1	L2	L3	L4		A		M	Weight [g]
									Unlocked	Locked	Unlocked	Locked		
AS22□1F-01-01PA	1/8"	1/8	13 (12.7)	7.2	12	19.1	26.2	18.8	30.3	28.9	25.1 (24.9)	23.7 (23.5)	13.3	10 (9)
AS22□1F-01-03PA	5/32"			8.2										
AS22□1F-01-07PA	1/4"			11.2										
AS22□1F-01-09PA	5/16"			13.2		20.8	27.9						14.2	10 (10)
AS22□1F-02-01PA	1/8"			7.2		22.4	29.5						15.6	11 (10)
AS22□1F-02-03PA	5/32"	1/4	17 (17.5)	8.2	13	20.9	30.2 (30.3)	22.6	36.6	35	29 (28.5)	27.4 (26.9)	13.3	19 (20)
AS22□1F-02-07PA	1/4"			11.2										
AS22□1F-02-09PA	5/16"			13.2										
AS22□1F-02-11PA	3/8"			15.5		23.4	32.7 (32.8)						14.2	20 (20)
AS32□1F-03-07PA	1/4"	3/8	21 (21.7)	11.2	16.6	21.8	33 (33.4)	28.7	42.3	40.7	34.7 (34.2)	33.1 (32.6)	13.3	38 (39)
AS32□1F-03-09PA	5/16"			13.2										
AS32□1F-03-11PA	3/8"			15.5										
AS42□1F-04-11PA	3/8"	1/2	27 (28.6)	15.5	18.8	26.7	37.9 (38.3)	28.2	50.8	49.2	40.4	38.8	15.6	66 (72)
AS42□1F-04-13PA	1/2"			19.3		30.9	45.3 (46.1)	34.7						

Note) The values in ( ) are for NPT thread.

# AS Series

# Made to Order

Please contact SMC for detailed dimensions, specifications and lead times.

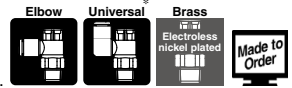

\* R, NPT threads are not available

## 1 Lubricant: Vaseline

**-X12**

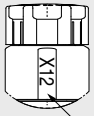

Laser printing

Example) AS2201F-G01-04A-X12

## 2 Grease-free (Seal: Fluorine-coated) + Restrictor (Without check valve)

**-X21**

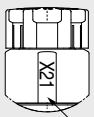

Laser printing

Example) AS2201F-G01-04A-X21

Note 1) Not particle-free

Note 2) This product is a restrictor without a check valve (no control direction). Be aware that all part numbers are for a meter-out type; there is no part number for a meter-in type.

Note 3) Only the needle and O-ring are fluorine-coated.

## 3 Restrictor (Without check valve)

**-X214**

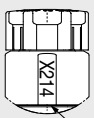

Laser printing

Example) AS2201F-G01-04A-X214

Note) This product is a restrictor without a check valve (no control direction). Be aware that all part numbers are for a meter-out type; there is no part number for a meter-in type.

## 4 Clean Series

**10-**

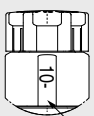

Laser printing

Example) 10-AS2201F-G01-04A

Note 1) Fluorine grease is used.

Note 2) The cleanliness class (ISO class) is 5.

Note 3) Applicable only to G thread type.

AS-F
TMH
ASD
AS
AS-FE
KE
AS-FG
AS-FP
AS-FM
AS-D
AS-T
ASP
ASN
AQ
ASV
AK
VCHC
ASR
ASQ

# Prior to Use

## Female Thread Conditions Applicable to Face Seal

1. Surface roughness of bearing surface: Rz 25 or less
2. Chamfer dimension:  $\phi D1$ , Seal bearing surface diameter:  $\phi D2$  (Refer to the table below.)
3. Female thread inclination angle:  $1^\circ$  or less
4. Counterbore diameter when the female thread is counterbored.:  $\phi D3$ 
  - Models with width across flats: Body width across flats x 1.1 or more
  - Models other than hexagon (Hexagon socket head male connector etc.): Body dimensions + 0.2 mm or more
  - \* The width across flats and the body dimensions differ depending on the model even when the same thread size is used. Refer to the dimensions in the catalog.
5. If oil content or sealant is sticking to the female thread, this may cause damage of the product. Remove it before piping.

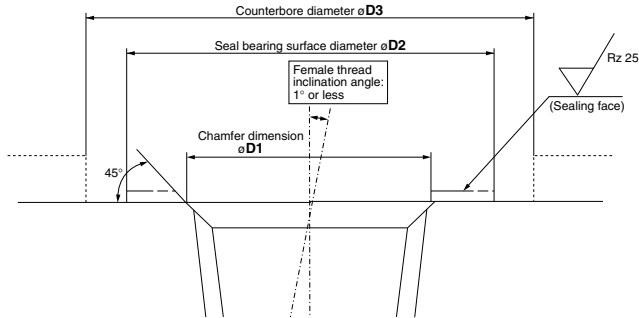

**Table 1**

Connection thread size	Chamfer dimension $\phi D1$ mm	Seal bearing surface diameter $\phi D2$ mm
R1/8	10.2 to 10.4	12 or more
R1/4	13.6 to 13.8	17 or more
R3/8	17.1 to 17.3	21 or more
R1/2	21.4 to 21.6	27 or more
NPT1/16	8.2 to 8.4	11.11 or more
NPT1/8	10.5 to 10.7	12.7 or more
NPT1/4	14.1 to 14.3	17.46 or more
NPT3/8	17.4 to 17.6	22 or more
NPT1/2	21.7 to 21.9	28.7 or more
G1/8	10.2 to 10.6	12 or more
G1/4	13.6 to 14.0	17 or more
G3/8	17.1 to 17.5	21 or more
G1/2	21.4 to 21.8	27 or more

### **⚠ Precautions**

For products that do not satisfy the female thread conditions shown above and the piping with a piping pitch narrower than the product dimension, use the current sealant type.

- \* The rubber parts of the face seal cannot be replaced.
- \* The rubber parts of the face seal may fall off by the air blow and they cannot be mounted again. Be careful not to perform the air blow.





# AS Series Specific Product Precautions 1

Be sure to read this before handling the products.

Refer to back page 50 for Safety Instructions and pages 543 to 546 for Flow Control Equipment Precautions.

## Design and Selection

### Warning

#### 1. Check the specifications.

The products in this catalog are designed to be used in compressed air systems (including vacuum) only. If the products are used in an environment where pressure or temperature is out of the specified range, damage and/or malfunction may result. Do not use under such conditions. (Refer to the specifications.)

Please contact SMC when using a fluid other than compressed air (including vacuum).

We do not guarantee against any damage if the product is used outside of the specification range.

#### 2. The products in this catalog are not designed for the use as stop valve with zero air leakage.

A certain amount of leakage is allowed in the product's specifications.

Tightening the needle to reduce leakage to zero may result in equipment damage.

#### 3. Do not disassemble the product or make any modifications, including additional machining.

It may cause human injury and/or an accident.

#### 4. The flow rate characteristics for each product are representative values.

The flow rate characteristics are characteristics of each individual product. Actual values may differ depending on the piping, circuitry, pressure conditions, etc.

#### 5. Sonic conductance (C) and critical pressure ratio (b) values for products are representative values.

**The speed controller's controlled flow values are with the needle fully open and free flow with the needle fully closed.**

#### 6. Check if PTFE can be used in application.

PTFE powder (Polytetrafluoroethylene resin) is included in the seal material for piping taper thread of male thread type. Confirm that the use of it will not cause any adverse effect on the system.

Please contact SMC if the Material Safety Data Sheet (MSDS) is required.

#### 7. Speed controller is designed to control the speed of the actuator.

When it is used for adjusting the flow rate of the air blow, use a restrictor without check valve function (X214 or X21).

## Mounting

### Warning

#### 1. Operation Manual

Install the products and operate them only after reading the Operation Manual carefully and understanding its contents. Also, keep the manual where it can be referred to as necessary.

#### 2. Ensure sufficient space for maintenance activities.

When installing the products, allow access for maintenance.

## Mounting

### Warning

#### 3. Tighten threads with the proper tightening torque.

When installing the products, follow the listed proper torque.

#### 4. After pushing the knob down to lock, confirm that it is locked.

It should not be possible to rotate the knob to the right or to the left. If the knob is pulled with force, it may break. Do not pull the knob with excessive force.

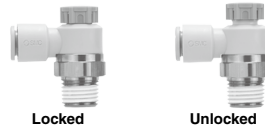

#### 5. Check the degree of rotation of the needle valve.

The products in this catalog are retainer type so that the needle is not removed completely. Over rotation will cause damage.

#### 6. Do not use tools such as pliers to rotate the knob.

It can cause idle rotation of the knob or damage.

#### 7. Verify the air flow direction.

Mounting backward is dangerous, because the speed adjustment needle will not work and the actuator may lurch suddenly.

#### 8. Adjust the speed by opening the needle slowly from the fully closed state.

Loose needle valves may cause unexpected sudden actuator lurching.

When a needle valve is turned clockwise, it is closed and actuator speed decreases. When a needle valve is turned counter-clockwise, it is open and actuator speed increases.

#### 9. Do not apply excessive force or shock to the body or fittings with an impact tool.

It can cause damage or air leakage.

#### 10. For handling One-touch fittings, refer to the Fittings and Tubing Precautions on pages 13 to 17.

#### 11. Tubing O.D. ø2

Tubing other than that from SMC cannot be used, because it may result in inability to connect the tube, air leakage after connecting the tube or disconnection of the tube.

#### 12. To install/remove the product, use an appropriate wrench to tighten/loosen at the supplied nut on body B.

Do not apply torque at other points as the product may be damaged. Rotate body A manually for positioning after installation.

AS-F
TMH
ASD
AS
AS-FE
KE
AS-FG
AS-FP
AS-FM
AS-D
AS-T
ASP
ASN
AQ
ASV
AK
VCHC
ASR
ASQ



# AS Series Specific Product Precautions 2

Be sure to read this before handling the products.

Refer to back page 50 for Safety Instructions and pages 543 to 546 for Flow Control Equipment Precautions.

## Mounting

### Warning

13. Do not use body A and/or elbow body for applications involving continuous rotation.

Body A and the fitting section may be damaged.

#### Elbow

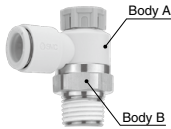

#### Universal

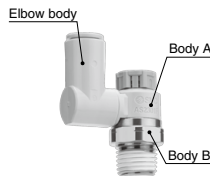

### Caution

#### For M5, 10-32UNF

#### Tightening method

First, tighten it by hand, then give it an additional 1/6 turn to 1/4 turn with a wrench. A reference value for the tightening torque is 1 to 1.5 N·m.

Note) Excessive tightening may damage the thread portion or deform the gasket and cause air leakage.

If the screw is too shallowly screwed in, it may come loose or air may leak.

#### Chamfered area for female thread

1. Conforming to ISO 16030 (air pressure fluid dynamics – connection – ports and stud ends), the chamfered dimensions shown in the table below are recommended.

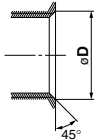

Female thread size	Chamfered dimension $\phi D$ (Recommended value)
M5	5.1 to 5.4
10-32UNF	5.0 to 5.3

2. This product has a stopper for fully close in rotating direction. Excess torque may break the stopper. Table below shows the maximum allowable torque of the knob.

Body size	Maximum allowable torque [N·m]
M5	0.05
1/8	0.07
1/4	0.16
3/8	0.2
1/2	0.4

3. When performing the piping work, turn the tightening tool in the horizontal direction to the hexagon across flats of the body B so that any moment is not applied to the body A. If the tool is in contact with the body A, this may cause the body B to come off.

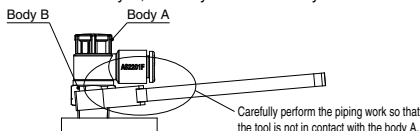

### Caution

#### For R, NPT Thread (With sealant)

#### Tightening method

1. The proper tightening torques of the fittings are as shown in the table below. As a guide, tighten by hand, then turn it two or three turns with a wrench. Check the dimensions of each product for the hexagon width across flats.

Connection thread size	Proper tightening torque [N·m]
NPT, R1/8	3 to 5
NPT, R1/4	8 to 12
NPT, R3/8	15 to 20
NPT, R1/2	20 to 25

#### Chamfered area for female thread

By chamfering as shown in the table below, machining of threads is easier and effective for burr prevention.

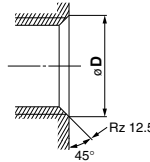

Connection thread size	Chamfered dimension $\phi D$ (Recommended value)	
	Rc	NPT, NPTF
1/8	10.2 to 10.4	10.5 to 10.7
1/4	13.6 to 13.8	14.1 to 14.3
3/8	17.1 to 17.3	17.4 to 17.6
1/2	21.4 to 21.6	21.7 to 21.9

\* For Uni thread, Rz 12.5 is necessary for sealing at the chamfered part.

#### For R, NPT, G Thread (Face seal type)

#### Tightening method

First, tighten the threaded portion by hand, then use a proper wrench, which could be suitable for the width across flats of the hexagon body, to tighten it further at a wrench tightening angle shown in the table below. For a tightening torque guide, refer to the table below. Check the dimensions of each product for the hexagon width across flats.

1. Tighten fittings with face seal using the proper tightening torques in the table below.

Connection thread size (R, NPT, G)	Proper tightening torque [N·m]
1/16, 1/8	3 to 5
1/4	8 to 12
3/8	15 to 20
1/2	20 to 25

2. Insufficient tightening may cause seal failure, or loosen the threads.

3. Reuse

- Normally, fittings with face seal can be reused 6 to 10 times.
- The seal ring cannot be replaced.



# AS Series

## Specific Product Precautions 3

Be sure to read this before handling the products.

Refer to back page 50 for Safety Instructions and pages 543 to 546 for Flow Control Equipment Precautions.

### Mounting

#### ⚠ Caution

For R, NPT, G Thread (Face seal type)

#### Chamfered area for female thread (Recommended value)

- Conforming to ISO 16030-2001, the chamfered dimensions shown in the table below are recommended. By chamfering as shown in the table below, machining of threads is easier and effective for burr prevention.

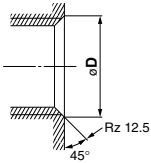

Nominal thread size	Chamfered dimension $\phi D$	
	Min.	Max.
1/8	9.8	10.2
1/4	13.3	13.7
3/8	16.8	17.2
1/2	21.0	21.4

- Use G external threads with G internal threads.

#### How to distinguish between G, R and NPT threads

For R, NPT thread

R: Without slit  
NPT: With slit

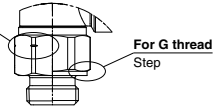

### For Uni Thread

#### Tightening method

- First, tighten the threaded portion by hand, then use a proper wrench, which could be suitable for the width across flats of the hexagon body, to tighten it further at a wrench tightening angle shown in the table below. For a tightening torque guide, refer to the table below.

#### Connection Female Thread: Rc, NPT, NPTF

Uni thread size	Wrench tightening angle after hand-tightening [deg]	Tightening torque [N·m]
1/8	30 to 60	3 to 5
1/4	30 to 60	8 to 12
3/8	15 to 45	14 to 16
1/2	15 to 30	20 to 22

#### Connection Female Thread: G

Uni thread size	Wrench tightening angle after hand-tightening [deg]	Tightening torque [N·m]
1/8	30 to 45	3 to 4
1/4	15 to 30	4 to 5
3/8	15 to 30	8 to 9
1/2	15 to 30	14 to 15

- The gasket can be reused up to 6 to 10 times.

#### Chamfered area for female thread

By chamfering as shown in the table below, machining of threads is easier and effective for burr prevention.

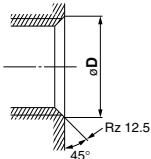

Connection thread size	Chamfered dimension $\phi D$ (Recommended value)		
	G	Rc	NPT, NPTF
1/8	10.2 to 10.6	10.2 to 10.4	10.5 to 10.7
1/4	13.6 to 14.0	13.6 to 13.8	14.1 to 14.3
3/8	17.1 to 17.5	17.1 to 17.3	17.4 to 17.6
1/2	21.4 to 21.8	21.4 to 21.6	21.7 to 21.9

\* For Uni thread, Rz 12.5 is necessary for sealing at the chamfered part.

### Piping Threads with Sealant

#### ⚠ Caution

- If the fitting is tightened with excessive torque, a large amount of sealant will seep out. Remove the excess sealant.
- Insufficient tightening may loosen the threads, or cause air leakage.
- Reuse
  - Normally, fittings with sealant can be reused 2 to 3 times.
  - To prevent air leakage through the sealant, remove any loose sealant stuck to the fitting by blowing air over the threaded portion.
  - If the sealant no longer provides effective sealing, wrap sealing tape over the sealant before reusing. Do not use the sealant in any form other than a tape type.
- Once the fitting has been tightened, backing it out to its original position often causes the sealant to become defective. Air leakage will occur.
- Use R external threads with Rc internal threads and NPT external threads with NPT internal threads.

### Piping

#### ⚠ Caution

- For handling One-touch fittings, refer to the Fittings and Tubing Precautions on pages 13 to 17.
- Preparation before piping
 

Before piping is connected, it should be thoroughly blown out with air (flushing) or washed to remove chips, cutting oil and other debris from inside the pipe.

#### 3. Winding of sealant tape

When screwing together pipes and fittings, etc., be certain that chips from the pipe threads and sealing material is used, not get inside the pipe. Also, when the sealant tape is do, leave approx. 1 thread ridges exposed at the end of the threads.

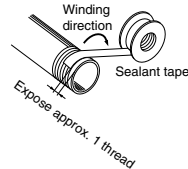

AS-F  
TMH  
ASD  
AS  
AS-FE  
KE  
AS-FG  
AS-FP  
AS-FM  
AS-D  
AS-T  
ASP  
ASN  
AQ  
ASV  
AK  
VCHC  
ASR  
ASQ



**Large Flow Type**

# Speed Controller with One-touch Fitting



Supports **cylinder port** size 1/8 and **high-speed long stroke** cylinder operation

■ Max. flow rate: 1000\*1 L/min (ANR)

\*1 For applicable tubing O.D.: ø8, ø10

- Increased orifice diameter

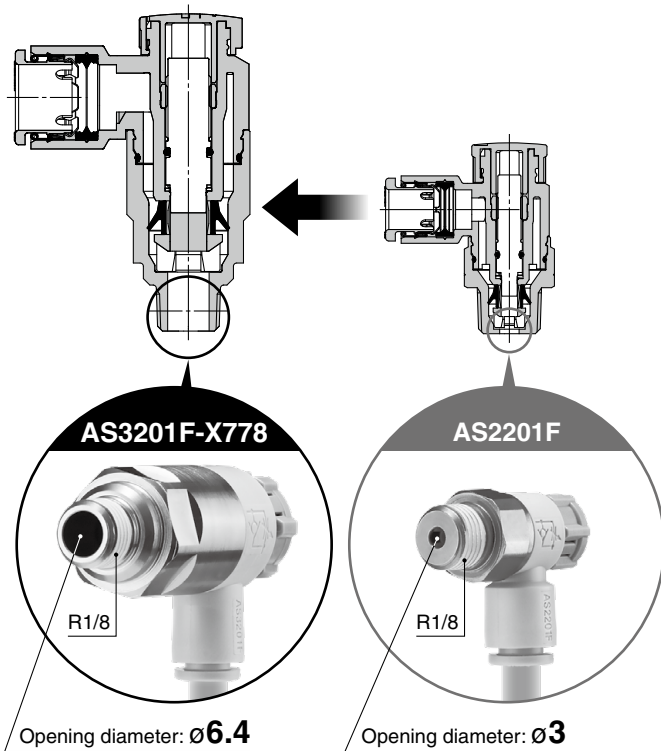

- Flow rate characteristics

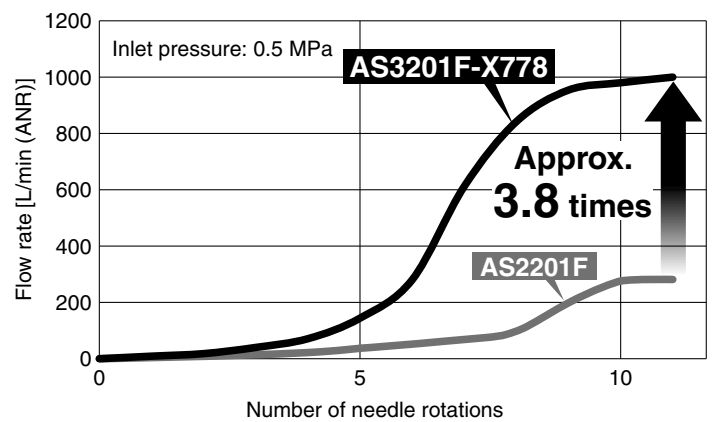

- Reduced parts and installation labor

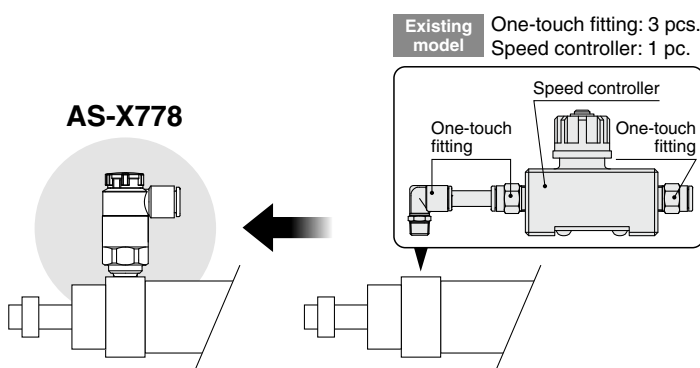

**Application example**

For the high-speed operation of take-out robots

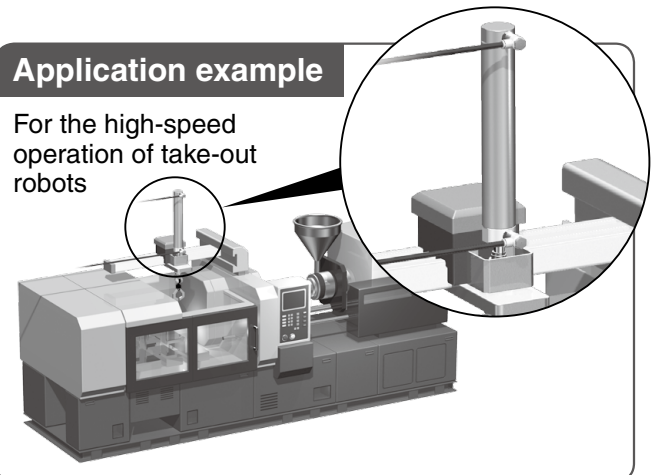

**AS3201F-01-□SA-X778**



# AS3201F-01-□SA-X778

## How to Order

AS3201F-01-**06**SA-X778

• Applicable tubing O.D.  
Metric size

06	ø6
08	ø8
10	ø10

## Specifications

Fluid	Air
Proof pressure	1.5 MPa
Control type	Meter-out
Operating pressure range	0.1 to 1 MPa
Ambient and fluid temperatures	-5 to 60°C (No freezing)
Applicable tubing material	Nylon, Soft nylon, Polyurethane*1, FEP, PFA

\*1 Use caution at the maximum operating pressure when using soft nylon or polyurethane tubing.  
(Refer to the **Web Catalog** for details on tubing.)

## Flow Rate Characteristics

AS3201F-01-06SA-X778

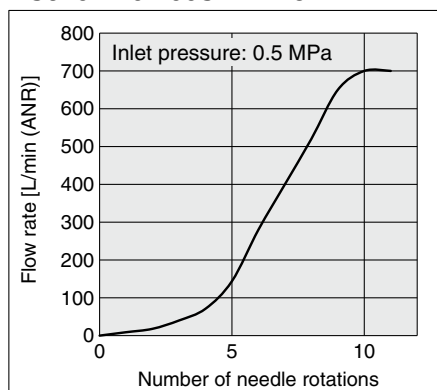

AS3201F-01-08SA-X778

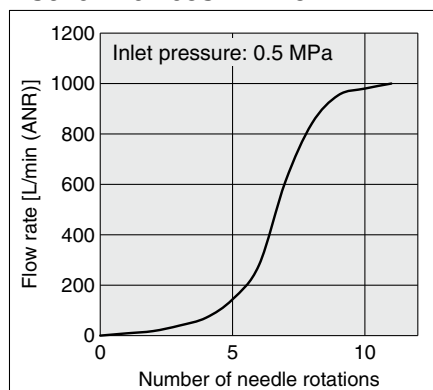

AS3201F-01-10SA-X778

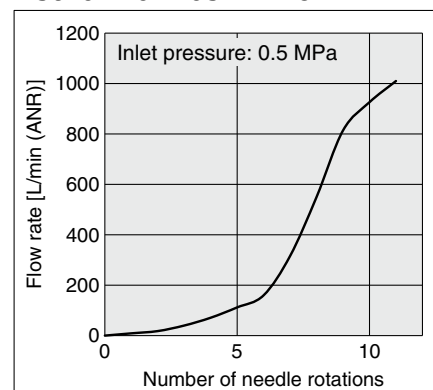

## Dimensions

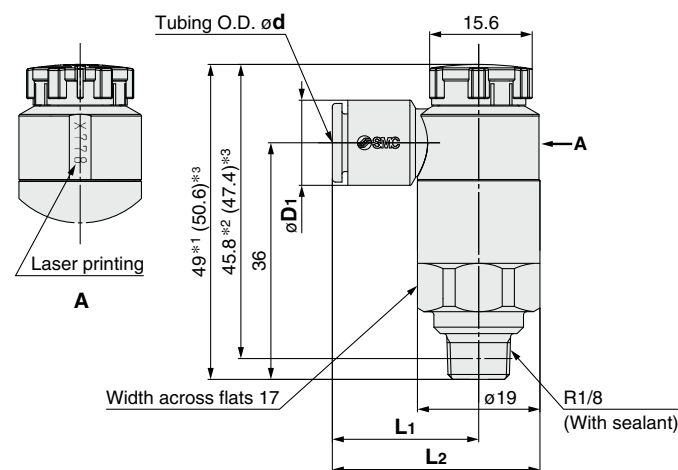

- \*1 Reference dimensions
- \*2 Reference dimensions of threads after installation
- \*3 Reference dimensions when locked

Model	d	D <sub>1</sub>	L <sub>1</sub>	L <sub>2</sub>
AS3201F-01-06SA-X778	6	10.4	32.1	36.4
AS3201F-01-08SA-X778	8	13.2	33	36.4
AS3201F-01-10SA-X778	10	15.9	37	35.7

## Warning

1. Use within the specified cylinder speed and kinetic energy ranges. Otherwise, cylinder and seal damage may occur.
2. If the driven object moves at high speeds or is heavy, it will be unfeasible for only the cylinder's cushion to absorb the shock. Therefore, provide a speed-reduction circuit to reduce the cylinder's speed before the thrust is applied to the cushion or an external shock absorber to dampen the shock.

**⚠ Safety Instructions** Be sure to read the "Handling Precautions for SMC Products" (M-E03-3) and "Operation Manual" before use.