

Differential pressure switch mechanical Model DPSM-550

Switzer data sheet DPSM-550

Applications

- Pumps
- Compressors
- Filters
- Evaporators
- Hydraulic systems
- Marine equipment
- Turbines

Special features

- Wide adjustable range
- Adjustable on-off differential
- Sturdy snap action switch
- High repeatability
- Dough mould compound (DMC) enclosure
- Weatherproof to IP67



Differential pressure switch mechanical,
model DPSM-550

Description

The model DPSM-550 is used in industrial control, monitoring and alarm applications. The switch point can be specified by the customer on site. The instrument can switch electrical loads of up to AC 230 V, 10 A. The DPSM-550 differential pressure switch offers many application possibilities with non-corrosive media like oil, water and air.

Ordering matrix

Model	Range (bar)	Adjustable differential		Maximum test pressure (bar)	
		Contact system / 1 SPDT microswitch	DPDT micro switch	Code 11	Code 41 & 22
K1	0.1 ... 1.5	0.15 ... 1.4	0.3 ... 1.7	15	25
K2	0.2 ... 4	0.3 ... 1.7	0.5 ... 2.1	15	25
K3	1 ... 6	0.5 ... 2.8	0.8 ... 3.0	25	45

Notes:

- For Ammonia service sensing shall be 316 SS bellows with treated steel wetted parts.
- Process connection : G 3/8 B standard. Others through adaptor.

Sensing element

- 11 Copper alloy (PB) Bellows with brass wetted Parts – standard
- 41 304 SS Bellows with brass wetted parts
- 22 316 SS Bellows with 316 SS wetted parts

Switching element

- C One SPDT contact system
- S One SPDT microswitch
- D DPDT microswitch

Electrical rating for contact system

Current consumption ¹⁾	Voltage	Current
Resistive load AC-1	AC 230 V, 50/60 Hz	10 A
Inductive load AC-15	AC 230 V, 50/60 Hz	4 A
Direct load DC-13	DC 230V	12W

1) Low port, falling pressure and High port, rising pressure

ONE SPDT Microswitch

- 15A Res. 125 / 250V AC
- 15A Ind. 125 / 250V AC
- 0.5A Res. 125V / 0.25A 250V DC
- 6A Ind. 30V / 0.05A 125V / 0.03A 250V DC

DPDT Microswitch

- 10A 125 / 250 V AC, 2A 480V AC
- 0.25A 250V DC

Enclosure

- D DMC Enclosure, weatherproof to IP:67 as per IS/IEC:60529-2001 – Std.
- A Die cast Aluminium housing, weatherproof to IP:67 as per IS/IEC:60529-2001

Standard version

Permissible ambient temperature

–40°C ... 70°C

Permissible medium temperature

- –20°C ... 70°C for code 11 and 41
- –20°C ... 170°C for code 22

Electrical entry

1/2" NPT(F)

Repeatability

± 1% FSR

Mounting

Back Panel / Wall / Pipe

Conformity

Generally to BS : 6134 : 1991

Model Number to be ordered as below

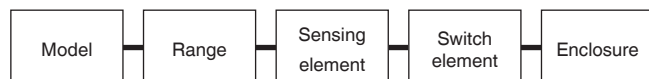

Example DPSM-550-K1-41-C-D

Model: K1

Range: 0.1 ... 1.5 bar

304 SS Bellows with brass wetted parts

1 SPDT contact system

DMC housing, weatherproof to IP:67 as per IEC:60529-2001

Dimensions in mm

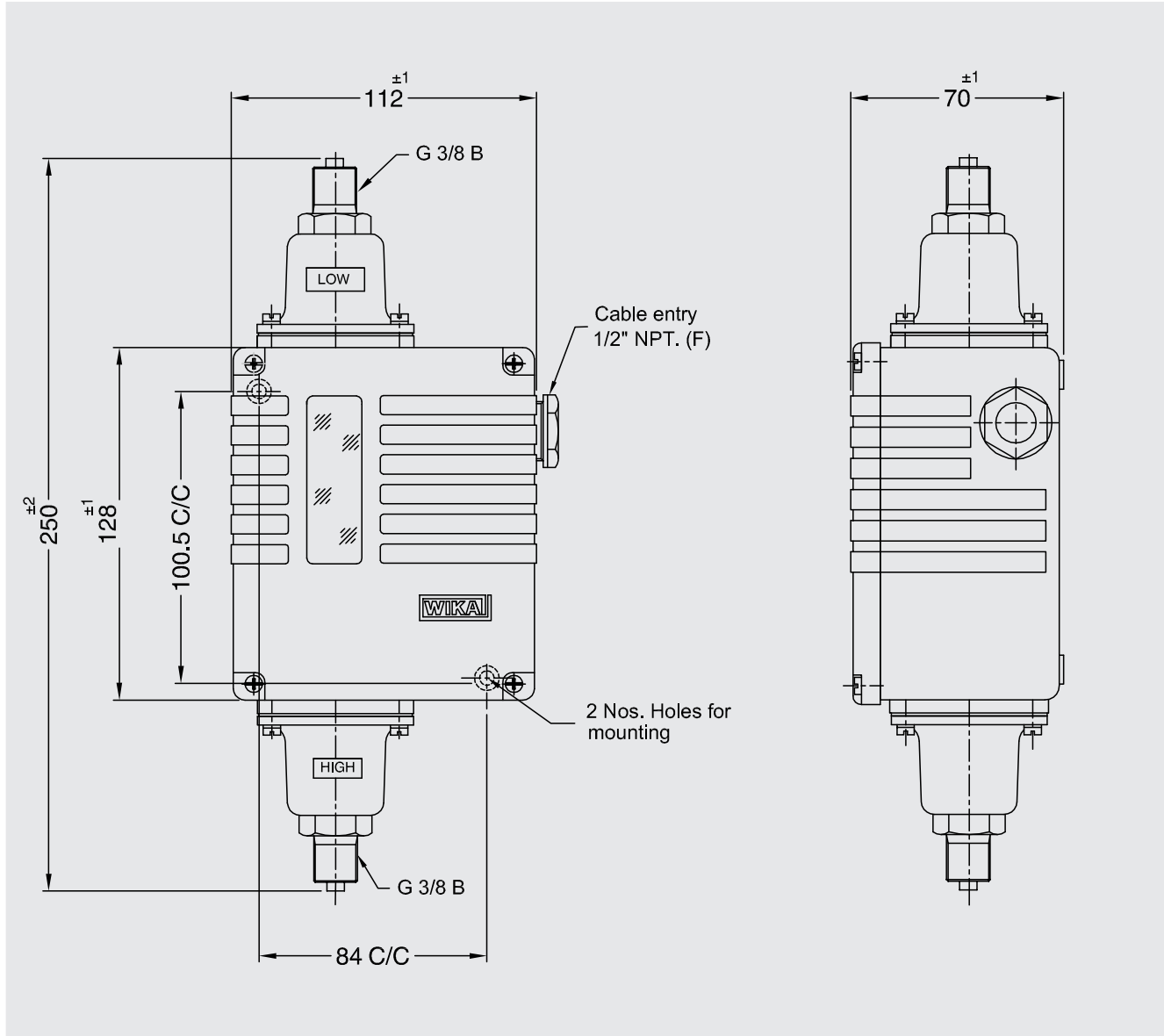

Ordering information

Model / Range / Sensing element / Switch element / Enclosure

10/2020.00 EN D7

2020 Switzer Process Instruments Pvt. Ltd., all rights reserved.
The specifications given in this document represent the state of engineering at the time of publishing.
We reserve the right to make modifications to the specifications and materials.

Switzer data sheet DP5M-550 · 10/2020

Page 3 of 3



Switzer Process Instruments Pvt. Ltd.

Regd. Off, Works-1 and Sales

128 SIDCO North Phase
Ambattur Industrial Estate, Chennai 600 098
Tel. +91 44 2625 2017 / 2018 / 4991 / 4324
sales@switzerprocess.co.in
www.switzerprocess.co.in

Works-2

C-123, Site No.1, Industrial Area
Bulandshahar Road, Ghaziabad 201 009