

DIAPHRAGM INSTRUMENTS



Manometer India manufactures quality differential pressure instruments designed to measure the difference in pressure between two points in a system and show it on a single dial instrument. A magnetic movement senses the differential pressure. The instruments has separate pressure and indicating chambers.

These diaphragm instruments can indicate small values of differential pressure even when used at high line pressures. These differential pressure instruments provide instantaneous and continuous information regarding system conditions helping in eliminating premature servicing of equipment, avoid unscheduled down time of costly processes and detect abnormal system conditions.

Switching Facility : Instruments can be supplied with reed switches to initiate alarms, activate other equipment, or shut the system down. Two switches are used when high and low limits are desired. Gauge-switch models provide the user with both, gauge readout and switch operation.

APPLICATIONS:

Monitor filter conditions, set filter by-pass, or initiate filter cleaning cycle. Check condition of pumps, heat exchangers, and other processing equipment. Detect abnormal and reverse flow conditions. Measure flow rates with venturi, orifice, or pitot tube.

400 DGC

Medium Convolute Diaphragm Instruments

SALIENT FEATURES

Cost effective and reliable.

Uses diaphragm sensor.

Easy to read dial instrument eliminates the accumulated errors of two instrument installations.

Differential pressure range from 25 mm to 600 mm H₂O.

Working pressures 35 bar.

Indicating mechanism isolated from pressure chamber.

Wide applications in air, gas and liquid media.

Zero migration between high and low pressures.

Manufactured in ISO 9002 certified plant.

Exported worldwide.

MAGNETIC PRINCIPLE



OPERATING PRINCIPLE

High and Low pressures are separated by a sensor assembly consisting of a magnet, diaphragm, and a range spring. The difference in pressure causes the sensor assembly to move in proportion to the change against a range spring.

A rotary magnet, located in a separate body cavity and isolated from the acting pressures, is rotated by magnetic coupling as per the linear movement of the sensor assembly. A pointer attached to the rotary magnet indicates differential pressure on the dial.

Switch : Reed switches are located adjacent to the pressure chamber and are activated by the magnetic field of the sensor assembly

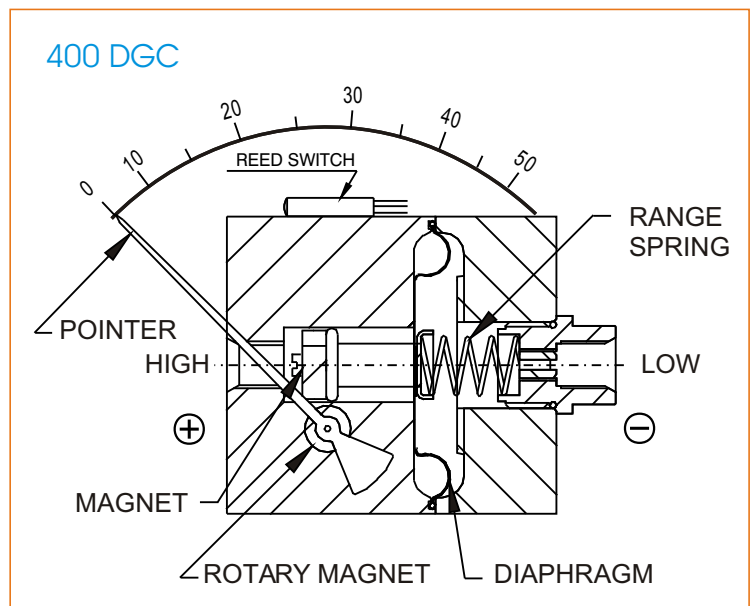

TECHNICAL DATA (MODEL 400 DGC)

Ranges	:	0-25 to 0-600 mm H ₂ O
Units of calibration	:	mm H ₂ O, mbar, IN H ₂ O, kPa.
Operating principle	:	Magnetic coupling with a convoluted diaphragm sensor.
Working pressure	:	35 bar
Accuracy	:	± 2 % of FSD (Ascending)
Dial sizes	:	3.5" (80mm), 4" (100mm), 4.5" (115mm) & 6"(150mm)
Body Material	:	Aluminium & SS-316.
Temperature.	:	80°C Max. for the media.
Protection	:	IP 65 for gauge
Migration of media	:	Zero migration between high and low pressures.
Connections	:	¼" NPT(F) or ¼" BSP(F)(on request, longer lead time)
Wetted parts	:	Diaphragm, ceramic magnet, SS 304 spring, Aluminium or SS-316 as per the gauge body
Seals	:	Buna-N (Standard), Viton
Porting	:	In-line (Standard), Bottom or Back
Switch	:	One or two SPST or one SPDT. Switches are field adjustable. The set points can be increased or decreased externally with simple screwdriver adjustments. When two switches are used, either switch can be adjusted independently.
Dial case	:	Stainless steel case and flange.
Window	:	Glass (Standard), Acrylic, Toughened glass on request.
Other options	:	Dual scale, colour band.

STANDARD DIMENSIONS (MODEL 400 DGC)

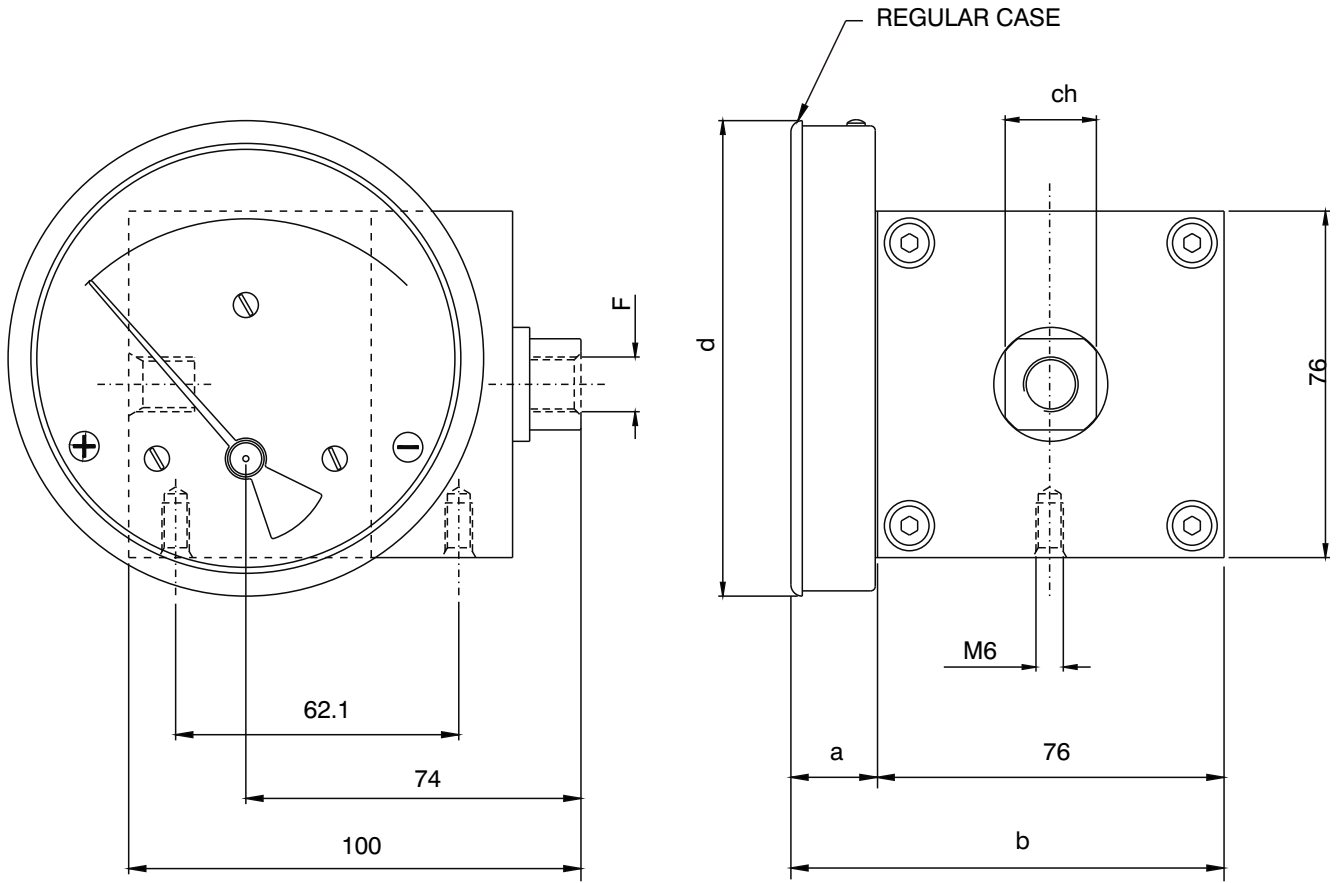

DIAL Ø	F	a	b	d	ch
80 (3.5")	1/4"BSP - 1/4"NPT	19	95	83	20
100 (4")	1/4"BSP - 1/4"NPT	19	95	104.3	20
115 (4.5")	1/4"BSP - 1/4"NPT	19	95	119.7	20
150 (6")	1/4"BSP - 1/4"NPT	19	95	154.3	20

STANDARD DIMENSIONS FOR FLANGE TYPE (MODEL 400 DGC)

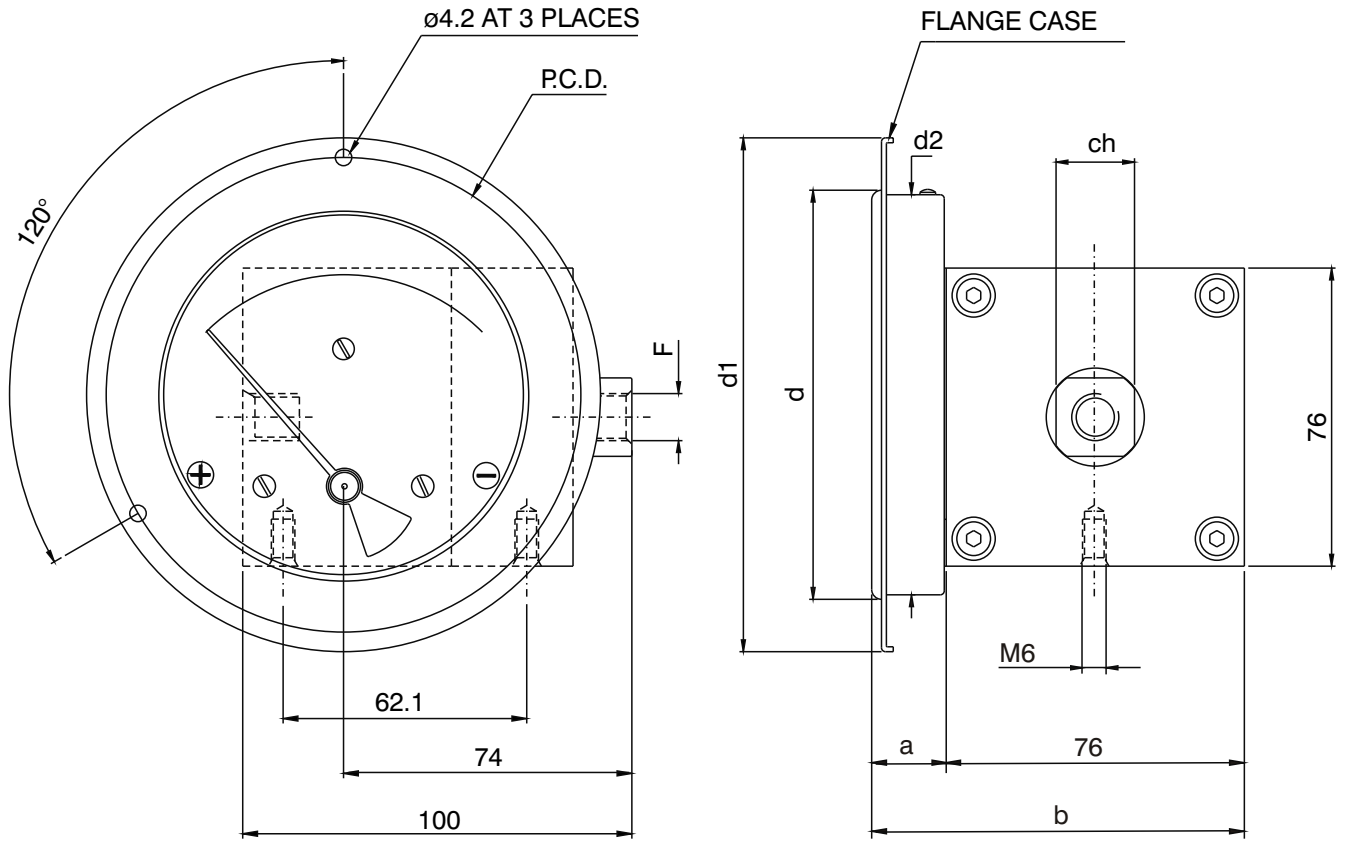

DIAL Ø	F	a	b	d1	d2	ch	p. c. d	d
80 (3.5")	1/4" BSP - 1/4" NPT	19	95	109	82.0	20	99	83.0
100 (4.0")	1/4" BSP - 1/4" NPT	19	95	131	102.0	20	121	104.3
115 (4.5")	1/4" BSP - 1/4" NPT	19	95	146	117.0	20	136	119.7
150 (6.0")	1/4" BSP - 1/4" NPT	19	95	181	152.5	20	171	154.3

* PANEL CUTOUT = d + 1 mm.

GAUGE + SWITCH WITH REED CONTACTS & DIN PLUG (MODEL 400 DGC)

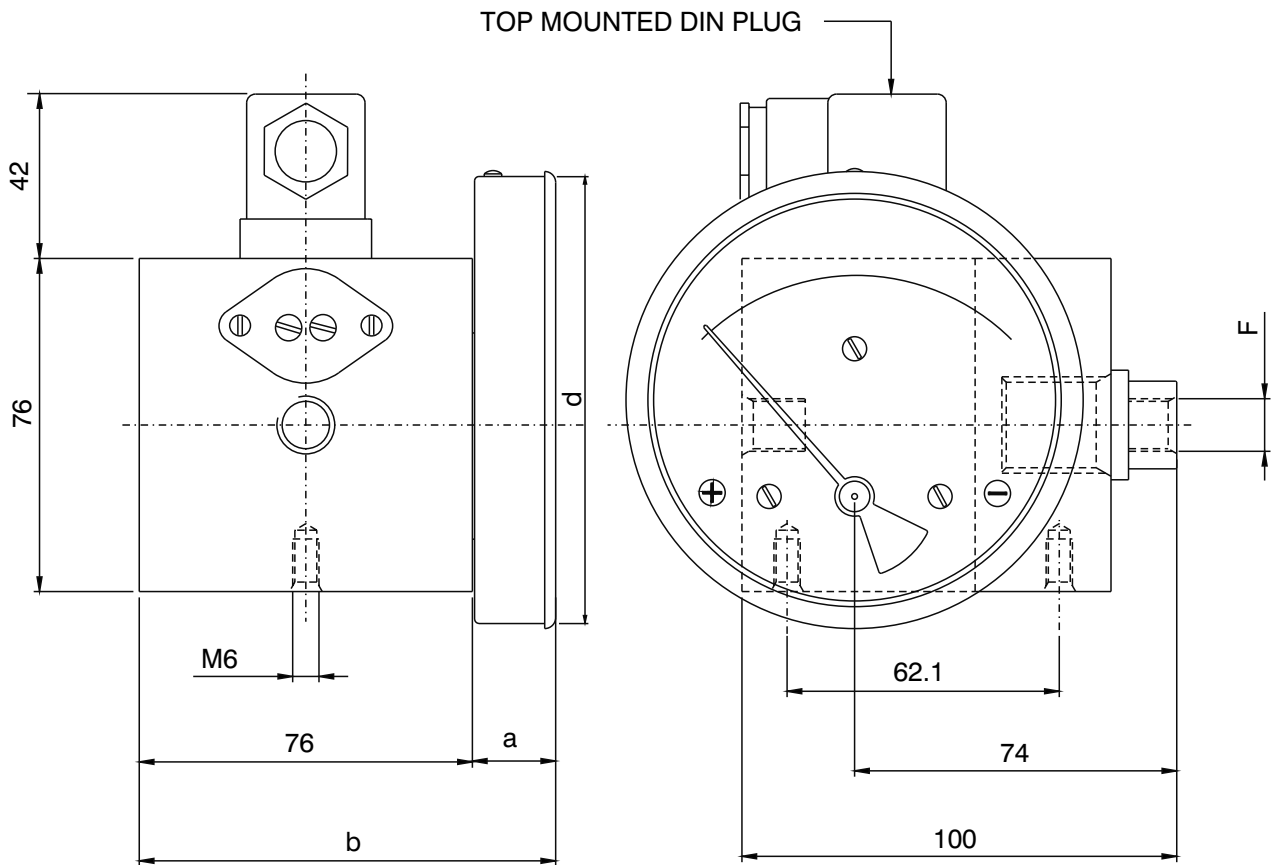

DIAL Ø	F	a	b	d
80 (3.5")	1/4"BSP - 1/4"NPT	19	95	83
100 (4")	1/4"BSP - 1/4"NPT	19	95	104.3
115 (4.5")	1/4"BSP - 1/4"NPT	19	95	119.7
150 (6")	1/4"BSP - 1/4"NPT	19	95	154.3

HOW TO ORDER A DIFFERENTIAL PRESSURE INSTRUMENT, MODEL 400 DGC

Example	Code	Descriptions
Series	400 DGC	
Type	G	G Gauge S Switch GS Gauge + Switch (<i>longer lead time</i>)
Body material	A	A Aluminium (<i>Anodized</i>) S SS-316 (<i>longer lead time</i>)
Dial size	3.5	3.5 3.5" (80 mm) 4.0 4.0" (100 mm) 4.5 4.5" (115 mm) 6.0 6.0" (150 mm)
Connection	4N	4B ¼" BSP (Female) (<i>on request, longer lead time</i>) 4N ¼" NPT (Female) ZZ Special connection sizes using adaptor
Porting	1	1 In-line (Standard) 2 Rear / Back 3 Bottom
Case type	SS	SS SS 304 with a rubber ring (standard) SF SS 304 flange with a rubber ring (standard flange)
Window	F	F Glass (standard) A Acrylic T Toughened glass
Seal	B	B Buna-N (standard) V Viton
Switch	0	0 None 1 One SPST, with a DIN plug* 3 Two SPSTs, with a DIN plug* 5 One SPDT, with a DIN plug*

SPST Specifications :
10 VA AC or DC (max)
150 V AC or DC (max)
0.5 Amp AC or DC (max)

SPDT Specifications :
5 VA AC or DC (max)
175 V AC or DC (max)
0.25 Amp AC or DC (max)

* **DIN plug** : we mount it on the top of gauge body.

Switch applicable for "GS" types only. Switches operate from 40 to 100% of the range & situated in the body. Switches are factory set, field adjustable.

Standard Ranges	0-0.5 kPa	mm H ₂ O	25	50	125	250	600
		IN. H ₂ O	1	2	5	10	25
		mbar	-	5	-	25	60
		kPa	0.25	0.5	1.25	2.5	6

Other ranges on request.

Options	C	0 None C Customer Logo D Dual scale E Colour band
---------	---	--

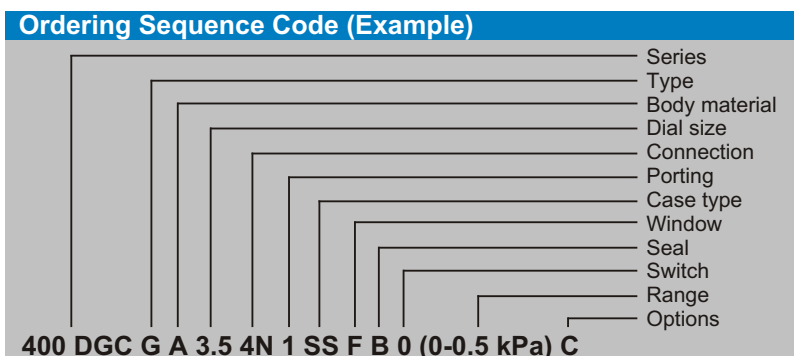

Specifications and dimensions given in this leaflet represent the state of engineering at the time of printing, modifications may take place and materials specified may be replaced by others without prior notice.